



TRANSCCELL TECHNOLOGY, INC.

# ***TC-200 Series***

## ***Digital Counting Scale***

### Operation Manual

Revision 1.4  
December 15, 2003

© 2001-2003 Transcell Technology, Inc.

Contents subject to change without notice.

Transcell Technology, Inc.  
975 Deerfield Parkway  
Buffalo Grove, IL 60089  
Tel (847) 419-9180  
Fax (847) 419-1515  
E-mail: [transcell@transcell.net](mailto:transcell@transcell.net)  
Web: [www.transcell.net](http://www.transcell.net)

# TABLE OF CONTENTS

	<u>Page</u>
Chapter 1: Introduction to the Transcell TC-200 Series Digital Counting Scale .....	5
Chapter 2: Getting Started.....	6
Chapter 3: Basics of Operation .....	8
3.1 Display .....	8
3.1.1 Vacuum Fluorescent Display (VFD) .....	8
3.2 Keyboard.....	9
3.2.1 Function and Numeric Keys .....	9
3.3 General Scale Operation .....	9
3.3.1 Weighing an Item.....	9
3.3.2 Taring an Item of Unknown Weight .....	10
3.3.3 Taring an Item of Known Weight .....	10
3.3.4 Clearing a Tare .....	10
3.3.5 Piece Counting .....	10
3.3.6 Clearing the Piece Count.....	10
Chapter 4: Advanced Features and Operation.....	12
4.1 Average Piece Weight Entry.....	12
4.1.1 APW Entry from Scale .....	12
4.1.2 APW Entry from Remote Scale .....	12
4.2 Memory Accumulator .....	12
4.2.1 Displaying the Memory Accumulator .....	12
4.2.2 Adding to the Memory Accumulator .....	12
4.2.3 Clearing the Memory Accumulator .....	12
4.3 Using the Target Value.....	13
Chapter 5: Configuration .....	14
5.1 Configuration Overview .....	14
5.2 Setup ("F") Menu .....	14
5.3 User ("A") Menu .....	15
5.3.1 Entering the User Menu.....	15
5.3.2 Navigating in the User Menu .....	15
5.3.3 Exiting the User Menu .....	16
5.4 User Menu Procedures.....	18
5.4.1 ID Number Entry (A8) .....	18
5.4.2 LF (Line Feeds) Number Entry (A9).....	18

Chapter 6:	Calibration.....	19
6.1	Calibration Overview.....	19
6.2	Calibration Mode.....	19
Appendix A:	Specifications.....	21
Appendix B:	Serial Port Information.....	22
B.1	COM1 Serial Port.....	22
B.1.1	Connecting the Serial Device.....	22
B.1.2	Default Print Format.....	22
B.1.3	Full Duplex Modes for COM1.....	23
B.1.3.1	Demand Mode.....	23
B.1.3.2	Continuous Mode.....	24
B.1.4	Transmit APW Mode.....	24
Appendix C:	Error Messages.....	25
C.1	Error Messages.....	25
C.1.1	Operator Errors.....	25
C.1.2	Calibration Errors.....	26

## LIST OF FIGURES

1-1	TC-200 Series Front Panel.....	5
2-1	TC-200 Back Panel.....	6
2-2	Latitude Compensation Zones (USA).....	7
3-1	TC-200 Display Detail.....	8
3-2	Function and Numeric Keys Layout.....	9
5-1	User Menu Key Assignments.....	14
5-2	User Menu Chart.....	14
B-1	Pin Assignments for COM1 Serial Port.....	22
B-2	Cable Diagram for Scale to Dot Matrix Printer.....	22
B-3	Cable Diagram for Scale to Computer.....	22
B-4	Default Print Format.....	23
B-5	Consolidated Controls Demand Mode.....	24
B-6	Consolidated Controls Continuous Mode.....	24

## LIST OF TABLES

1-1	TC-200 Series Product Matrix.....	5
3-1	TC-200 Series Annunciator Definitions.....	8
3-2	TC-200 Sampling Limits.....	11
5-1	User Menu Descriptions.....	17
6-1	Minimum / Recommended Calibration Test Weights.....	20
B-1	Recognized Host Commands.....	23

## Electromagnetic Compatibility Statement for Europe

PRODUCT	TC-200	Directives with which this equipment complies:
Harmonized Standards applied:		<b>EMC 89/336/EEC</b> EMC Directive
		<b>EMC 92/31/EEC</b> EMC Directive
		<b>EMC 93/68/EEC</b> EMC Directive
<b>EN 55011:1998 (Class B)</b>		
<b>EN 61000-3-2:1995</b>	<b>+A1:1998 +A2:1998</b>	
<b>EN 61000-3-3:1995</b>		
<b>EN 45501: 1994</b>	<b>IEC801-2:1991</b>	
	<b>IEC801-3:1984</b>	
	<b>IEC801-4:1988</b>	
	<b>Short Time Power Reductions</b>	
<b>EN 55024: 1998</b>	<b>EN 61000-4-5:1995</b>	
Year in which CE mark affixed	2001	Date of issue    Oct 2001

## Electromagnetic Compatibility Statement for North America

This equipment has been tested and found to comply with the limits for a Class A digital device, pursuant to Part 15 of the FCC Rules. These limits are designed to provide reasonable protection against harmful interference when the equipment is operated in a commercial environment. This equipment generates, uses and can radiate radio frequency energy and, if not installed and used in accordance with the instructions manual, may cause harmful interference to radio communications. Operation of this equipment in a residential area is likely to cause harmful interference in which case the user will be required to correct the interference at his/her own expense.

**CHAPTER 1: INTRODUCTION TO THE TRANSCELL TC-200 SERIES DIGITAL COUNTING SCALE**

The Transcell Model TC-200 Series Digital Counting Scale is an easy to use, high-resolution counting scale featuring keyboard tare and unit weight entry. It is equipped with many useful features that are normally found on more expensive scale products, including memory accumulator and target values.

The scale is available in four avoirdupois weight capacities and four metric weight capacities. Table 1-1 shows the TC-200 series product matrix.

Prior to using the scale, please read this user's guide carefully and completely. Store the manual in a safe and convenient place so it will be available if you have questions concerning the operation of the scale.

MODEL	CAPACITY / GRADUATION	MODEL	CAPACITY / GRADUATION
TC-200-6	6 x 0.0005 lb	TC-200-3M	3000 g x 0.2 g
TC-200-12	12 x 0.001 lb	TC-200-6M	6000 g x 0.5 g
TC-200-30	30 x 0.002 lb	TC-200-15M	15 x 0.001 kg (1 g)
TC-200-60	60 x 0.005 lb	TC-200-30M	30 x 0.002 kg (2 g)

**TABLE 1-1: TC-200 Series Product Matrix**

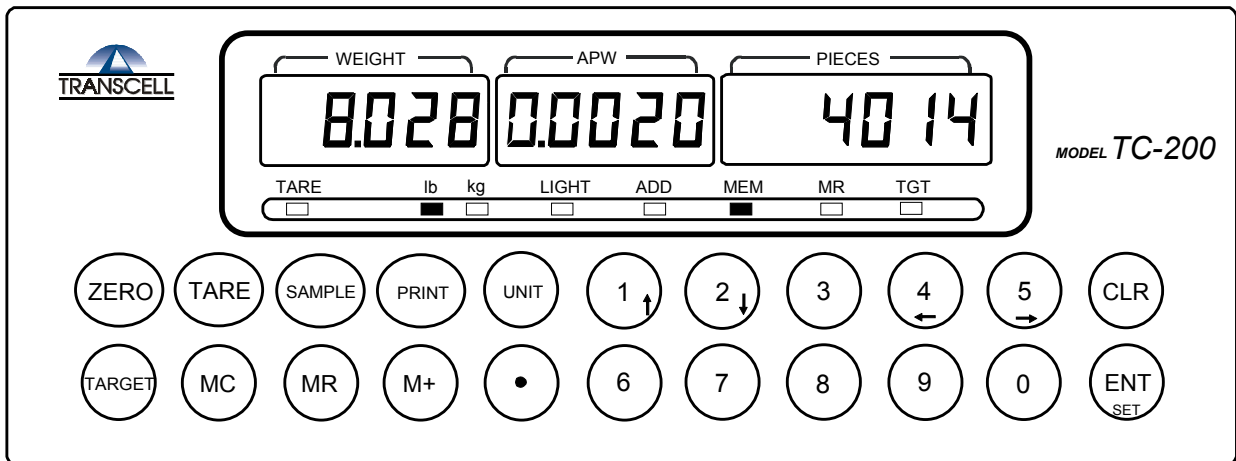

**FIGURE 1-1: TC-200 Series Front Panel**

## CHAPTER 2: GETTING STARTED

After unpacking the scale, a small amount of preparation is required before the scale can be used. Please refer to Figure 2-1 below as needed.

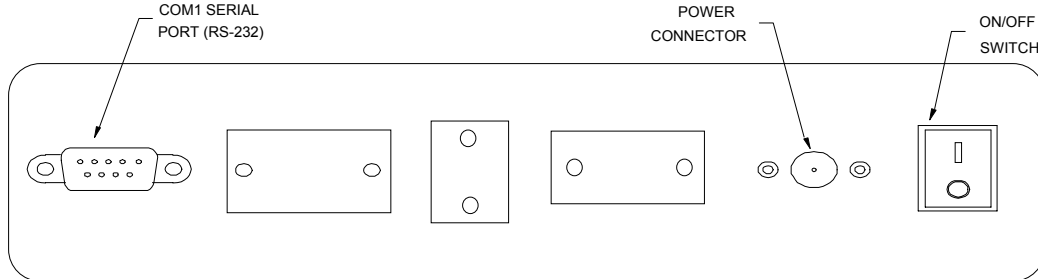

**Figure 2-1: TC-200 Back Panel**

- Step 1. Position the scale in its area of intended use. Observe the following guidelines for suitable location.
1. Choose a firm, stable floor or table.
  2. Do not share an AC outlet with electrical noise producing equipment, such as refrigeration units. This includes products with electrical motors and/or relays.
  3. Do not place the scale in an area with changing ambient temperature and/or high humidity.
  4. Do not place the scale in an area prone to exposure to direct sunlight, wind, or dust.
  5. Do not place the scale in an area with vibrating equipment.
- Step 2. Install the AC Adapter.
1. After placing the scale in its area of use, locate the Model A41408 (North America) or Model SA10-1208U (International) AC Adapter.
  2. Connect the female end of the AC Adapter to the connector on the rear of scale, and then plug the adapter into an AC outlet. **Make sure that the AC voltage appearing at the wall outlet matches the input voltage marked on the AC adapter.**
- Step 3. If applicable, install the serial printer or a computer to the COM1 serial port.
1. Connect the printer or computer to the COM1 port using the optional serial cable. See Appendix B for cabling requirements and pinouts.
  2. Configure the communication parameters and select the device type as detailed in Section 5.3.
- Step 4. Turn the scale's AC power on to begin use. When the scale is switched on for the very first time, the message "**d-ZonE**" appears on the display. Press the numeric key corresponding to the correct geographic area in the map shown in Figure 2-2 then press the **ENTER** key to save. **Note** – If there is no corresponding geographic area, enter "0" then press the **ENTER** key. No gravitation adjustment will be performed.

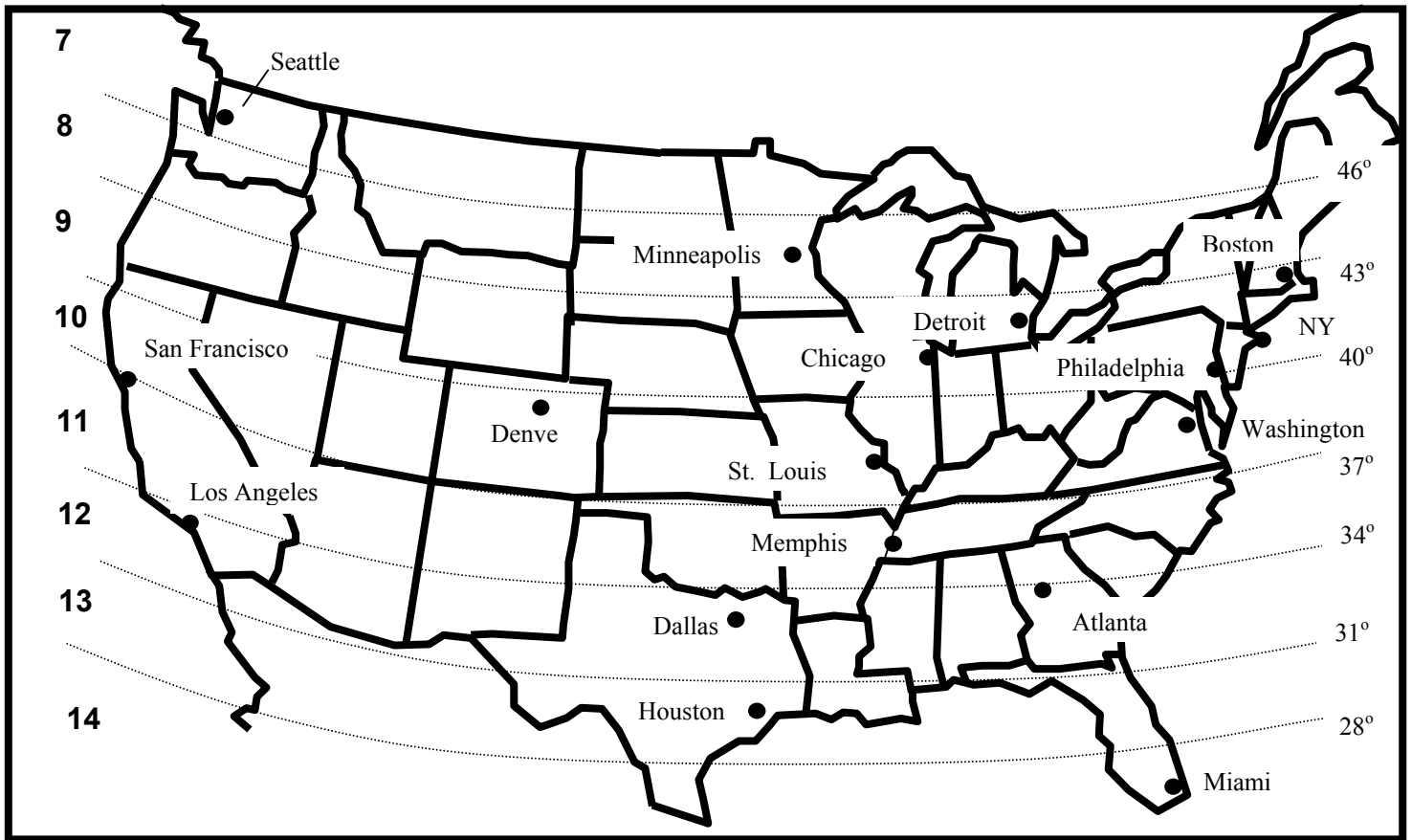

Figure 2-2 : Latitude Compensation Zones (USA)

## CHAPTER 3: OPERATION

### 3.1 DISPLAY

The Model TC-200 scale utilizes a 16 digit VFD (Vacuum Fluorescent Display) to display the weight and system information.

#### 3.1.1 VACUUM FLUORESCENT DISPLAY (VFD)

Figure 3-1 shows the display detail of the VFD. Table 3-1 lists the various annunciators you may see and their meanings.

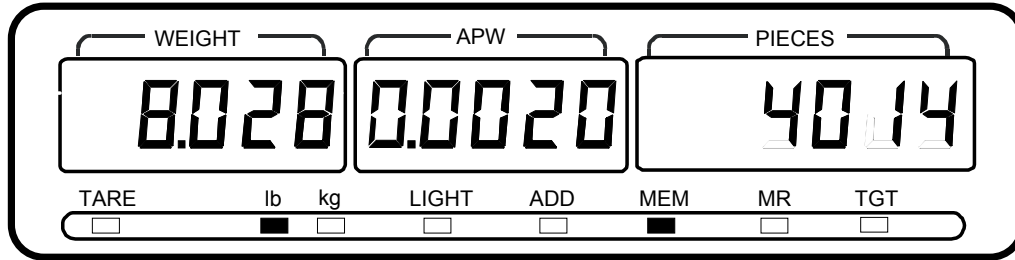

**FIGURE 3-1: TC-200 Display Detail**

Annunciator	MEANING
TARE	Indicates that a tare has been established in the system.
LB, KG	Indicates the unit of the displayed weight.
LIGHT	Indicates that the APW of the items you are sampling or manually entering is too light for the scale to process accurately.
ADD	Indicates that total weight of the items you are sampling is too light for the scale to process accurately.
MEM	Indicates that the value of the piece count accumulator is greater than zero.
MR	Indicates that the scale is displaying the contents of the piece count accumulator.
TGT	Indicates that the number of pieces on the scale meets or exceeds the programmed target value.

**TABLE 3-1: TC-200 Series Annunciator Definitions**



## 3.2 KEYBOARD

The keyboard is composed of twelve function keys and ten numeric keys. Refer to Figure 3-2 for the overall layout and key locations.

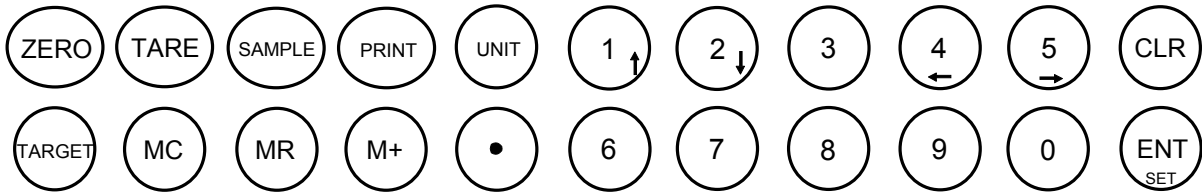

**FIGURE 3-2: Function and Numeric Keys Layout**

### 3.2.1 FUNCTION AND NUMERIC KEYS

**ZERO** - This key sets the scale to display zero.

**TARE** - This key is used to establish a Tare provided the scale is not at or below Gross zero. See Sections 3.3.2 and 3.3.3 below for more information.

**SAMPLE** – This key is used to sample the items currently on the scale’s platter for piece counting. Refer to Section 3.3.5 for more information.

**PRINT** - This key is used to send weight information out to the serial interface port provided the scale is in a state of stability.

**UNIT** – This key toggles the scale between pound (lb) and kilogram (kg) weight units.

**TARGET** - This key is used to set a target for filling and check weighing. Refer to Section 4.3 for more information.

**MC** - This key is used to clear the piece count accumulator.

**MR** - This key is used to briefly display the contents of the piece count accumulator.

**M+** - This key is used to add the currently displayed number of pieces to the piece count accumulator.

**Decimal Point** - This key is used to enter a decimal point when entering numeric values.

**0-9** – These keys are used to enter numeric and alphanumeric data into the scale.

**CLR** - This key is used primarily to erase a keyed-in value from the display in case an error has been made. This key is also used to clear the current APW (Average Piece Weight) from the scale.

**ENT** - This key is used to set a keyed-in value from the display as the new APW (Average Piece Weight). See Section 4.1 for more information. This key is also used to save settings while in the system setup menus. See Chapter 5 for more information.

## 3.3 GENERAL SCALE OPERATION

### 3.3.1 WEIGHING AN ITEM

1. If necessary, press the Zero key to obtain a weight reading of zero.
2. Place the object to be weighed on the scale’s platter and allow the weight indication to stabilize. If the item weight exceeds the scale’s weight capacity, it displays “o o o o o”.

3. Read the weight shown on the display.

**Note:** If you wish to change the unit of measure, press the Unit key.

### **3.3.2 TARING AN ITEM OF UNKNOWN WEIGHT**

To weigh an item in a container, the weight of that container must first be subtracted from the overall weight to obtain an accurate weight reading. This is known as taring.

1. If necessary, press the Zero key to obtain a weight reading of zero.
2. Place the empty container on the scale's platter and allow the weight indication to stabilize.
3. Press the Tare key. The TARE light comes on and the scale displays a weight reading of zero.
4. Place the material to be weighed in the container and allow the weight indication to stabilize.
5. Read the weight shown on the display.

### **3.3.3 TARING AN ITEM OF KNOWN WEIGHT**

If the weight of the container or object is known, you may enter this weight via the keyboard. This value must be rounded to the nearest scale division. For example, on a 60 x 0.005 lb scale, you must enter the tare weight value to the nearest 0.005 lb.

1. Using the numeric keys, key-in the known tare weight and press the Tare key. The display shows minus weight and turns the TARE annunciator on.
2. Place the material to be weighed in the container and allow the weight indication to stabilize.
3. Read the weight shown on the display.

### **3.3.4 CLEARING A TARE**

1. To clear a tare, press the ZERO key at any time. The TARE annunciator disappears and the gross weight is displayed.

### **3.3.5 PIECE COUNTING**

This mode is used to indicate the number of pieces of an item you have placed on the scale's platform. To ensure accuracy, the parts you are counting must be consistent in weight.

The scale uses the sampling method to determine the average piece weight (APW) of the items you wish to count. When sampling items, always count the parts in your hand and place them on the platform all at once. If the APW of the items is too light or the total weight of the sample is too light, accuracy cannot be guaranteed. You will get an error message, but piece counting will still be allowed. Consult Table 3-2 for minimum piece weights and sample weights.

1. If the items you will be counting require a container, you must first tare the container off by pressing the TARE key. The scale switches to TARE mode and sets the displayed weight to zero.
2. Place the sample items on the platform all at once.
3. Using the numeric keys, key-in the number of items you have placed on the

scale's platter.

### 3.3.6 CLEARING THE PIECE COUNT

1. To clear the piece count, either press the CLR key to erase the sample or repeat the steps in Section 3.3.5.

<b>MODEL</b>	<b>Capacity / Graduation</b>	<b>Minimum Piece Weight</b>	<b>Minimum Sample Weight</b>
TC-200-6	6 x 0.0005 lb	0.0004 lb	0.0125 lb
TC-200-12	12 x 0.001 lb	0.0008 lb	0.025 lb
TC-200-30	30 x 0.002 lb	0.0016 lb	0.050 lb
TC-200-60	60 x 0.005 lb	0.004 lb	0.125 lb
TC-200-3M	3000 g x 0.2 g	0.16 g	5 g
TC-200-6M	6000 g x 0.5 g	0.4 g	12.5 g
TC-200-15M	15 x 0.001 kg (1 g)	0.8 g	25 g
TC-200-30M	30 x 0.002 kg (2 g)	1.6 g	50 g

**TABLE 3-2: TC-200 Sampling Limits**

## CHAPTER 4: ADVANCED FEATURES AND OPERATION

### 4.1 AVERAGE PIECE WEIGHT ENTRY

If you already know the Average Piece Weight or APW of the items you wish to count, then use the following procedure.

#### 4.1.1 APW ENTRY FROM SCALE

1. Using the numeric and decimal point keys, key-in the actual Average Piece Weigh value.
2. Press the ENT key. If the APW is large enough, the scale will now display the number of pieces on the scale. If it does not, the scale briefly displays an error message, but still allows piece counting. Please see Appendix C for an explanation of the error messages.

**NOTE:** If the scale displays an “Error 10” message, the unit weight of the items you wish to count is too light for your scale to process at all.

#### 4.1.2 APW ENTRY FROM REMOTE SCALE

To use this method, you must have either a TC-100 or a PBS Series scale connected to the TC-200. See Appendix B for cabling requirements.

**NOTE:** The TC-100 or PBS Series scale must be configured for “Transmit APW Mode”. See TC-100 or PBS Series manual for more information.

1. Perform the sampling on the remote scale.
2. Press the PRINT key on the remote scale. If the APW is large enough, the TC-200 scale will now display the number of pieces on the scale. If it does not, the TC-200 scale briefly displays an error message, but still allows piece counting. Please see Appendix C for an explanation of the error messages.

### 4.2 MEMORY ACCUMULATOR

Your scale comes equipped with a handy memory accumulator, which can be used in conjunction with the piece counting feature. As with a hand-held calculator, the memory accumulator can be added to, displayed and cleared at anytime.

**NOTE:** Make sure the scale is in piece counting mode. If it is not, follow the sampling procedure found in Section 3.3.5 or the alternative sampling procedure found in Section 4.1.

#### 4.2.1 DISPLAYING THE MEMORY ACCUMULATOR

1. Press the MR key. The scale briefly displays the total number of pieces.

#### 4.2.2 ADDING TO THE MEMORY ACCUMULATOR

1. Press the M+ key. The scale adds the current number of pieces to the memory accumulator.

#### 4.2.3 CLEARING THE MEMORY ACCUMULATOR

1. Press the MC key.

### 4.3 USING THE TARGET VALUE

This function works in conjunction with the piece counting feature and allows your scale to act as a checkweigher. This is useful if you are filling a container with a pre-determined amount of items.

To use, you must enter a target value. For example, if you wish to fill a bottle with 100 items you would set your target value to 100.

If the number of items on the platform matches or exceeds the target value, the scale flashes the TGT annunciator and beeps.

1. First, make sure the scale is in piece counting mode. If it is not, follow the sampling procedure found in Section 3.3.5 or the alternative sampling procedure found in Section 4.1.
2. Use the numeric keys to key-in the target value then press the TARGET key.
3. Place items on scale until the scale signals that the items are equal to or greater than the target value.

**NOTE:** To exit the target function, press the TARGET key once.

Press the SAMPLE key. If the sample meets the limits shown in Table 3-2, the scale will now display the number of pieces on the scale. If it does not, the scale lights one of the error annunciators but still allows piece counting. If this occurs, you should use a higher sample amount to achieve better piece count accuracy. Please see Table 3-1 for an explanation of the error annunciators.

**NOTE1 :** If the scale displays a “Error 10” message, the unit weight of the items you wish to count is too light for your scale to process at all.

**NOTE2 :** To further increase the accuracy of this operation, the TC-200 uses a feature called "Automatic Average Weight Improvement" (AAWI). This feature automatically updates the current APW when small quantities of pieces – two to current piece count – are added to the platform. For example, if the current piece count shown on the display is 10, then adding 2 to 10 more pieces on the platform at the same time will trigger AAWI. When this occurs, the Unit Wt. Screen will show dashes briefly then update the new APW value.<sup>1</sup>

---

<sup>1</sup> This feature is available only when the A10 setting is enabled (see Chapter 5). The A10 menu may not appear on some earlier units. If your scale does not have an A10 menu, then AAWI is automatically turned on for you and is not configurable.

## CHAPTER 5: CONFIGURATION

### 5.1 CONFIGURATION OVERVIEW

The scale contains two main setup menus: The Setup (“F”) menu configures the factory settings for your scale. The User (“A”) menu configures the COM1 serial communication port and enables some user options. The Setup and User menus consist of several menu selections, each with its own sub-menu of choices.

To set up the scale, you must first enter the appropriate menu mode. Once there, four of the front panel keys become directional navigators to move around in the menus, and one key is used to save or SET the selections.

### 5.2 SETUP (“F”) MENU

#### 5.2.1 ENTERING THE SETUP MENU

1. Power off the scale by toggling the ON/OFF switch.
2. Press and hold the numeric 0 key while powering the scale back on. When the scale shows ” F 1”, you are in Setup Menu mode and you may release the 0 key.

#### 5.2.2 NAVIGATING IN THE SETUP MENU

Use the directional keys shown in Figure 3-1 to move around in the Setup Menu Chart shown in Figure 3-2 on the following page. Detailed descriptions of the Setup Menu can be found in Chapter 4.

1. To move to a new “F” heading, use the 4 (left) or 5 (right) key to move right or left in the Setup Menu Chart.
2. To move to the selection level, press the 2 (down) key once. The current saved selection is shown.
3. To view the available selections for the current “F” heading, use the 4 (left) or 5 (right) key to move through the selection field.
4. To save a new selection, press the ENT (Set) key. To exit without saving, press the 1 (up) key to return to the current “F” heading.
5. Repeat Steps 2 through 5 until the Setup Menu is programmed.

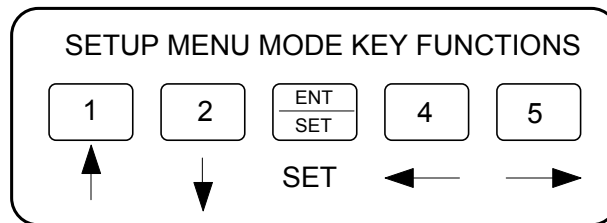
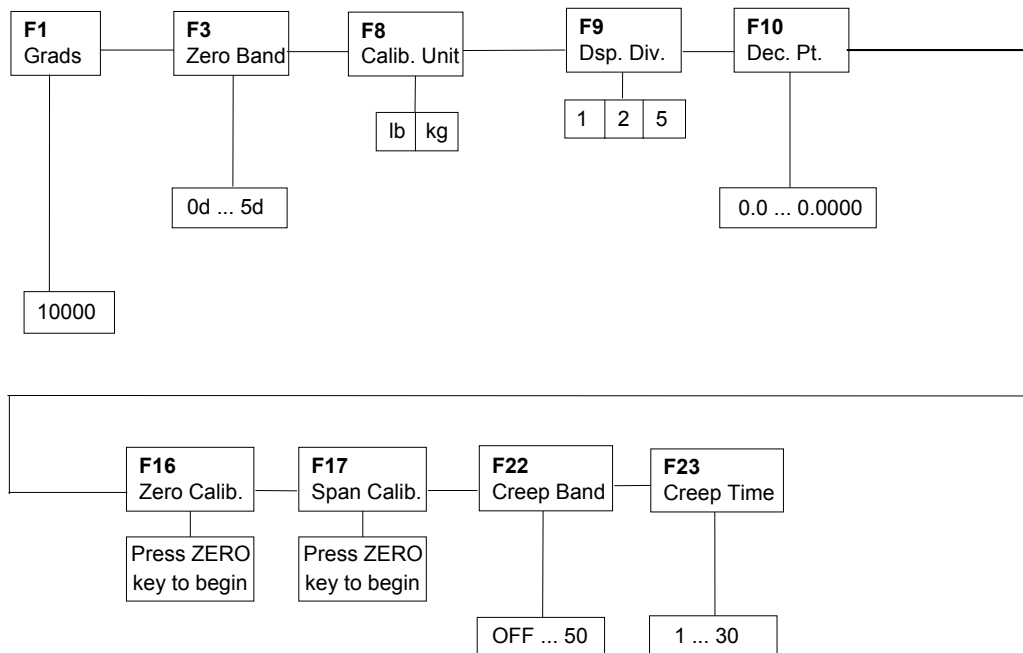

Figure 5-1: Setup Menu Key Assignments

Continued =>



**Figure 5-2: Setup Menu Chart**

### 5.2.3 NOTES ON THE SETUP MENU

1. Detailed descriptions of the setup menu parameters can be found in Chapter 5 of this manual.

### 5.2.4 EXITING THE SETUP MENU

1. Power off the scale by toggling the ON/OFF switch.
2. Power on the scale as normal. The display will go through a digit check, then settle into Normal Operating mode. All front panel keys will now return to their normal mode of operation.

## 5.3 USER (“A”) MENU

### 5.3.1 ENTERING THE USER MENU

1. Toggle the ON/OFF switch to the OFF (0) position.
2. Press and hold the 8 key while powering back on the scale. When the scale shows “ A 1” you are in User Menu mode and you may release the 8 key.

### 5.3.2 NAVIGATING IN THE USER MENU

Use the directional keys shown in Figure 5-1 to move around in the User Menu Chart shown in Figure 5-2 on the following page. Detailed descriptions of the User Menu can be found in Table 5-1.

6. To move to a new "A" heading, use the 4 (left) or 5 (right) key to move right or left in the User Menu Chart.
7. To move to the selection level, press the 2 (down) key once. The current saved selection is shown.
8. To view the available selections for the current "A" heading, use the 4 (left) or 5 (right) key to move through the selection field.
9. To save a new selection, press the ENT (Set) key. To exit without saving, press the 1 (up) key to return to the current "A" heading.
10. Repeat Steps 2 through 5 until the User Menu is programmed.

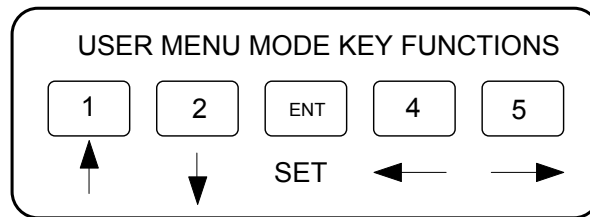

**Figure 5-1: User Menu Key Assignments**

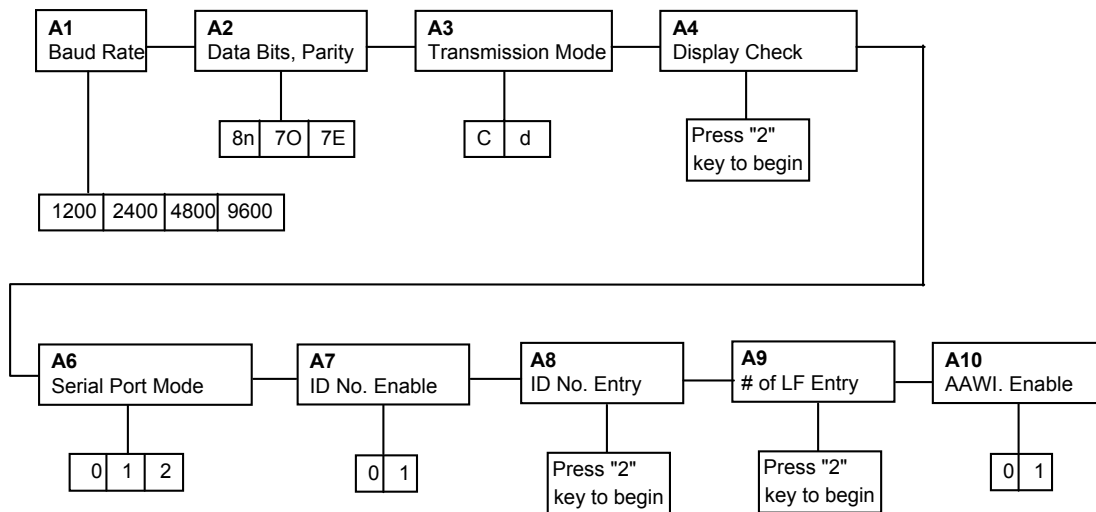

**Figure 5-3: User Menu Chart<sup>2</sup>**

### 5.3.3 EXITING THE USER MENU

1. Toggle the ON/OFF switch to the OFF (0) position.
2. Turn the scale back on without holding down any keys. The display will go through a digit check, then settle into Normal Operating mode. All front panel keys will now return to their normal mode of operation.

<sup>2</sup> Some earlier units will not have an A10 menu.



NAME/CODE	DESCRIPTION	CODE/VALUE
<b>A1</b> Baud Rate	Selects the baud rate for data transmission through the serial port.	1200    2400 4800 <b>9600</b> √
<b>A2</b> Data Bits and Parity	Selects the number of data bits and parity of serial transmission. "8n" = 8 data bits with no parity bit "7O" = 7 data bits with odd parity bit "7E" = 7 data bits with even parity bit	<b>8n</b> √ 7O 7E
<b>A3</b> Mode of Serial Transmission	Selects when data will be sent out of the serial port to a printer or computer: "C" = Continuous mode; send data continuously "d" = Demand mode; send data when a PRINT command is issued from the printer, computer, or indicator.	C <b>d</b> √
<b>A4</b> Display Check	Actuates the function that illuminates all digit segments, decimal points, and LED annunciators in a test sequence. Pressing the <b>2</b> key to scroll down one level begins the test sequence.	Press <b>2</b> key to begin sequence
<b>A6</b> Serial Port Mode	Selects the mode of the RS-232C serial port: "0" = Full Duplex Mode "1" = Print Ticket Mode "2" = Transmit APW Mode	<b>0</b> √ 1 2
<b>A7</b> ID No. Enable	Allows the ID No. to be disabled in the printout. Valid only when <b>A6</b> is set to "1". "0" = Disable the ID No.                      "1" = Enable the ID No.	<b>0</b> √ 1
<b>A8</b> ID No. Entry	Actuates the function that allows entry of a new ID No. Valid only when <b>A6</b> is set to "1". Pressing the <b>2</b> key to scroll down one level begins the sequence.	0 - 999999 (123456 is default)
<b>A9</b> No. of Line Feeds	Actuates the function that allows entry of the desired number of line feeds to be printed after the printout. Valid only when <b>A6</b> is set to "1". Pressing the <b>2</b> key to scroll down one level begins the sequence.	0 – 99 (5 is default)
<b>A10</b> AAWI Enable	Allows the AAWI feature to be enabled during piece counting. "0" = Disable AAWI                      "1" = Enable AAWI	<b>0</b> √ 1

**Table 5-1: User Menu Descriptions**

## 5.4 USER MENU PROCEDURES

This section provides instructions for all of the User Menu procedures.

### 5.4.1 ID Number Entry (A8)

1. While in the User Menu mode, scroll to "**A 8**", then scroll down once using the 2 key to enter the ID Number menu.
2. The display will momentarily show "**ET ID**", followed by the current ID number value.
3. Use the front panel numeric keys to key-in the actual ID Number value. If you make a mistake, press the CLR key to clear your entry and start over.
4. After entering the exact value, press the ENT key to save the ID Number value. The display will show "**END ID**" momentarily, then revert back up to A8.

### 5.4.2 LF (Line Feeds) Number Entry (A9)

1. While in the User Menu mode, scroll to "**A 9**", then scroll down once using the 2 key to enter the Line Feeds menu.
2. The display will momentarily show "**ET LF**", followed by the current line feeds value.
3. Use the front panel numeric keys to key-in the actual line feeds value. If you make a mistake, press the CLR key to clear your entry and start over.
4. After entering the exact value, press the ENT key to save the line feeds value. The display will show "**END LF**" momentarily, then revert back up to A9.

## CHAPTER 6: CALIBRATION

### 6.1 CALIBRATION OVERVIEW

Your TC-200 scale ships from the factory fully calibrated. There is no need to calibrate the scale unless you feel that it has become inaccurate. It is a good idea to check the calibration of your scale from time to time with a precision test weight. Transcell recommends that you perform a new calibration on your digital scale at least once a year.

During calibration, at least two values are saved in the scale's memory – the zero value (deadweight) and the up to three span values (test weights). See Table 6-1 for a listing of minimum and recommend test weights.

### 6.2 CALIBRATION MODE

1. Toggle the ON/OFF switch to the OFF (0) position.
2. Press and hold the ZERO key while powering back on the scale. When the scale shows "o Zone" you are in Calibration mode and you may release the ZERO key.
3. Press the ENT key. The scale shows "C 0" on the middle screen and displays a value on the right hand screen. The "C 0" indicates that the scale is prompting for the zero calibration value. The value to the right is for troubleshooting purposes only. Allow a 20-minute warm-up period for the load cell and electronic components to become thermally stable.
4. Remove all items from the scale's platter. Press ZERO to zero the value.
5. Press the ENT key to save the zero point value. The scale shows "0.000" on the left screen, "C 1" on the middle screen and a value on the right screen. The "C 1" indicates that the scale is prompting for the first span calibration value. The value to the right is for troubleshooting purposes only.
6. Use the numeric keys to enter the test weight value. Please note that the decimal point is fixed so that if you are entering, for example, 6 lb, you need to type "6" followed by zeroes until the "6" is to the left of the decimal point.
7. Place the test weight(s) onto the scale's platter, then press the ENT key. If the calibration was successful, the display will show "END C1" momentarily, then prompt for the next span calibration value.
8. If you wish to use up to two more calibration test weights, repeat Step 7 twice. Each subsequent test weight must be greater than the last. If you do not wish to use more calibration test weights, simply press ENT twice. The scale then automatically enters Normal Operating Mode by performing a countdown test. Remove the test weight from the platter

**NOTE:** If you encounter a failure, consult Appendix C for possible causes and remedies.

<b>MODEL</b>	<b>Capacity / Graduation</b>	<b>Minimum Test Weight</b>	<b>Recommended Test Weight</b>
TC-200-6	6 x 0.0005 lb	0.06 lb	4 lb to 6 lb
TC-200-12	12 x 0.001 lb	0.12 lb	8 lb to 12 lb
TC-200-30	30 x 0.002 lb	0.3 lb	20 lb to 30 lb
TC-200-60	60 x 0.005 lb	0.6 lb	40 lb to 60 lb
TC-200-3M	3000 x 0.2 g	30 g	2 kg to 3 kg
TC-200-6M	6000 x 0.5 g	60 g	4 kg to 6 kg
TC-200-15M	15 x 0.001 kg (1 g)	150 g	10 kg to 15 kg
TC-200-30M	30 x 0.002 kg (2 g)	300 g	20 kg to 30 kg

**TABLE 6-1: Minimum / Recommended Calibration Test Weights**

## APPENDIX A: SPECIFICATIONS

### CONSTRUCTION:

**Housings:** Grey ABS  
**Sub-Platform:** ABS  
**Platter:** Stainless Steel  
**Feet:** Non-skid Hard Rubber

### DISPLAY:

14 Character, 7-Segment VFD

### KEYPAD:

22-key Tactile Keypad

### OVER CAPACITY ANNUNCIATION:

103% of Full Scale Capacity

### OPERATING TEMPERATURE RANGE:

32°F to 104°F  
(0°C to 40°C)

### POWER SOURCE:

AC Adapter, 12VDC, 800 mA,  
included

### COM1 SERIAL PORT:

Full Duplex RS-232, DSUB9F

### WEIGHT:

Net Weight: 11.0 lb (4.9 kg)  
Shipping Weight: 16 lb (7.2 kg)

---

### PHYSICAL DIMENSIONS:

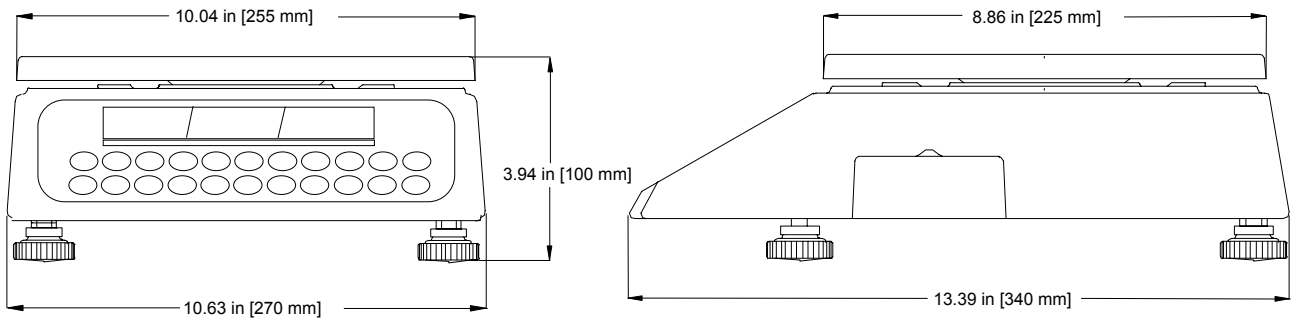

## APPENDIX B: SERIAL PORT INFORMATION

### B.1 COM1 SERIAL PORT

#### B.1.1 CONNECTING THE SERIAL DEVICE

The COM1 serial port is a full duplex RS-232 port designed for connection to one of the following devices:

- Serial receipt printer (dot matrix)
- Computer
- Remote display
- TC-100 Scale or PBS Precision Balance (to receive APW)
- TC-2001, TC-2005 or TC-2001 Scale (to transmit APW)

Figure B-1 shows the serial port pinout. Figure B-2 shows a suggested cable diagram for a serial printer. Figure B-3 shows a suggested cable diagram for a PC-type computer. The cable shown in Figure B-3 is a standard Transcell cable – Model NMC-1.

1. Plug the serial device cable (not included) directly into the DSUB9 serial port connector.

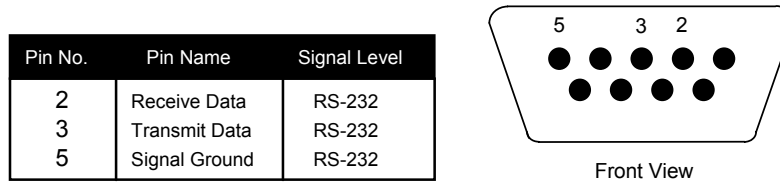

**Figure B-1: Pin assignments for the COM1 serial port connector**

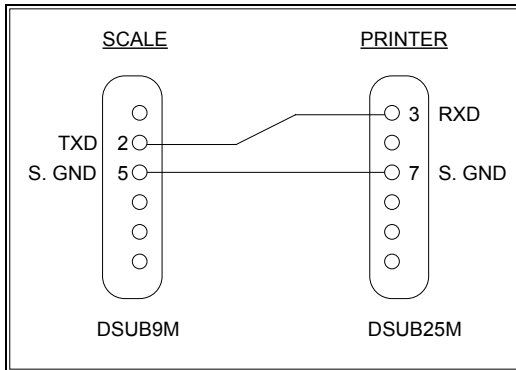

**FIGURE B-2: Cable Diagram for Scale to Dot Matrix Printer**

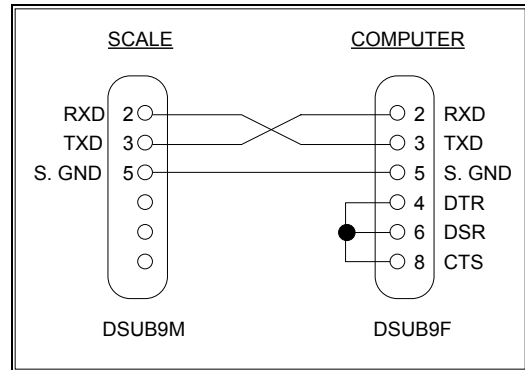

**FIGURE B-3: Cable Diagram for Scale to Computer**

### B.1.2 DEFAULT PRINT FORMAT

Figure B-4 shows the fixed format of the print format. NOTE: The TARE and NET fields are blank when a tare has not yet been established in the system. The PCS field is blank when an APW has not yet been established in the system.

ID. NO.	123456
GROSS	5.000 LB
TARE	1.480 LB
NET	3.520 LB
PCS	3520

FIGURE B-4: Default Print Format

### B.1.3 FULL DUPLEX MODES FOR COM1

#### B.1.3.1 DEMAND MODE

The Demand mode allows control from a host device, usually a PC, and can be activated by pressing the Print key. Figure B-5 shows the serial data format for the Demand Mode. Table B-1 shows the recognized host commands.

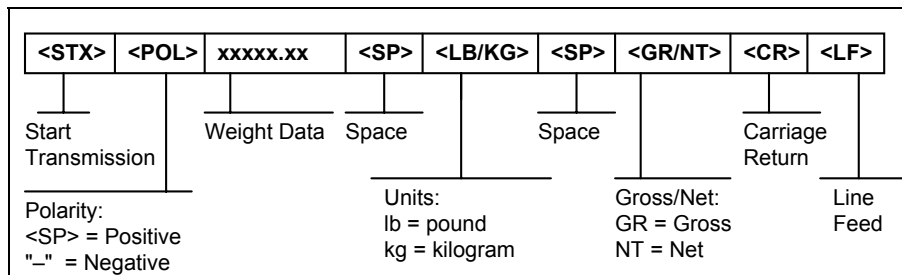

FIGURE B-5. Consolidated Controls Demand Mode

- “P” - This command is sent to the scale to print the indicated display. The scale will not respond if the scale is in motion, positive overload or negative overload.
- “Z” - This command is sent to the scale to zero the scale. If the scale is in motion, the scale will wait until a state of equilibrium is achieved. The scale will not respond at all if the scale is in positive overload or negative overload.
- “T” - This command is sent to the scale to tare the scale. If the scale is in motion, the scale will wait until a state of equilibrium is achieved. The scale will not respond at all if the scale is in positive overload or negative overload. The scale will also not respond if it displaying a negative gross value.

**TABLE B-1. Recognized Host Commands**

**B.1.3.2 CONTINUOUS MODE**

The Demand mode is used to interface to computers, scoreboards and other remote devices requiring constant data updating. The transmission occurs at the end of each display update. Figure B-6 shows the serial data format for the Continuous Mode.

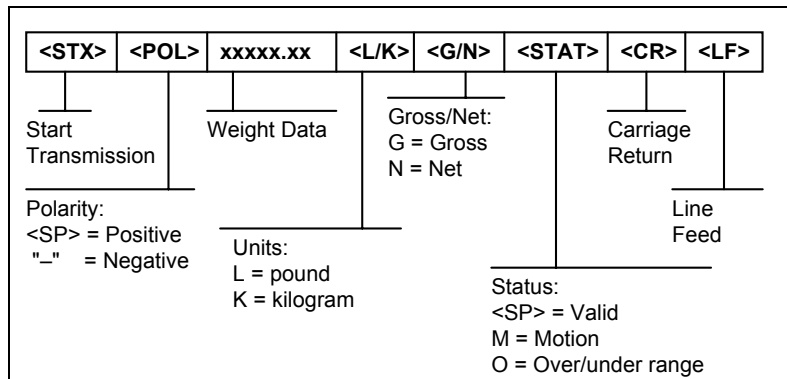

**FIGURE B-6. Consolidated Controls Continuous Mode**

**B.1.4 TRANSMIT APW MODE**

The Transmit APW Mode is designed specifically for connection to any of the following TC Series scale models:

- TC-2001
- TC-2005
- TC-2010

Its purpose is to allow APW's derived on the TC-200 scale to be transmitted to a larger scale for actual piece counting there. Just press the PRINT key at any time on the TC-200 to initiate the transmission. Consult your TC-2001, TC-2005 or TC-2010 scale manual for more information.



## APPENDIX C: ERROR MESSAGES

### C.1 ERROR MESSAGES

If the scale encounters an error condition, it will display a message alerting the operator. A description of each display follows:

#### C.1.1 OPERATOR ERRORS

<i>Message</i>	<b>Explanation</b>
□□□□□□	Indicates that the weighing capacity of the selected scale has been exceeded.
Err 9	Span calibration value has been lost. Re-calibrate scale.
Err 10	Indicates that there is not enough internal resolution to calculate the APW of an item. This means that the items you are counting are too light for the scale to process at all.
Err 11	Keyed-in sample value is equal to zero or is a fractional value. Key-in a valid sample value.
Err 12	Indicates that the APW of the items you are sampling or manually entering is too light for the scale to process accurately.
Err 13	Indicates that total weight of the items you are sampling is too light for the scale to process accurately.
Err 14	The keyed-in value for APW is equal to zero or exceeds the capacity of the scale. Key-in a valid APW value.
tErr 6	Indicates that the tare weight value you are entering is not rounded to the nearest scale division. For example, you cannot enter 0.01 lb for a 0.05 lb increment scale.
tErr 1	Indicates that the tare weight value or APW value you are entering exceeds the capacity of the scale.

### C.1.2 CALIBRATION ERRORS

<b>Message</b>	<b>Explanation</b>
Err 0	Indicates that the test weight value you have chosen exceeds the scale's capacity.
Err 1	Indicates that the test weight value you have chosen is less than 1% of the scale's capacity.
Err 2	Occurs when you do not place the test weight on the scale during calibration. Can also indicate that there is an internal error in the scale.

## LIMITED WARRANTY

Seller warrants that the TC Series Digital Counting Scale line will conform to written specifications, drawings, and other descriptions made by the manufacturer, including any modifications thereof. The Seller warrants the goods against faulty workmanship and defective materials. If any goods fail to conform to these warranties, Seller will, as its sole and exclusive liability hereunder, repair or replace such goods if they are returned within the following warranty period:

### **Twelve (12) months from date of shipment from manufacturer.**

These warranties are made upon the following TERMS and CONDITIONS:

This warranty is limited to the original equipment manufactured by TRANSCCELL TECHNOLOGY, INC. Items not covered under this warranty are batteries and normal wear items like connectors, shrouds, front panels and fuses.

For the first sixty (60) days from the date of installation, the warranty covers parts, on-site labor, and limited travel time and mileage. (3 hrs/150 miles maximum per occurrence).

After sixty (60) days, the warranty covers the cost of replacement parts only.

However, at the discretion and prior approval of TRANSCCELL, certain equipment may be returned, freight pre-paid, for repair, free of any parts or labor charges.

TRANSCCELL's responsibility is confined to repair, replacement or credit of equipment of parts. The warranty does not extend coverage to labor, material, freight or service charges involved in removal, shipping or reinstallation of equipment or parts.

### CONDITIONS WHICH VOID LIMITED WARRANTY:

This warranty shall not apply to equipment which:

- A. Examination of such goods discloses that the nonconformity exists and was caused by accident, misuse, neglect, alteration, improper installation improper or unauthorized repair, improper testing, or an act of GOD including lightning and such goods have not been modified, altered, or changed by any person other than the Seller or its duly authorized repair agents.

Transcell Technology, Inc. will have a reasonable time to repair or replace such goods.

THESE WARRANTIES EXCLUDE ALL OTHER WARRANTIES, EXPRESS OR IMPLIED, ORAL OR WRITTEN, INCLUDING WITHOUT LIMITATION WARRANTIES OF MERCHANTABILITY OR FITNESS FOR A PARTICULAR PURPOSE. SELLER WILL NOT IN ANY EVENT BE LIABLE FOR INCIDENTAL OR CONSEQUENTIAL DAMAGES.

IN ACCEPTING THIS WARRANTY, THE PURCHASER OR BUYER AGREES TO WAIVE ANY AND ALL OTHER CLAIMS FOR RIGHT TO WARRANTY FROM TRANSCCELL TECHNOLOGY, INC. SHOULD THE SELLER BE OTHER THAN TRANSCCELL TECHNOLOGY, INC., THE BUYER AGREES TO LOOK ONLY TO THE SELLER FOR WARRANTY CLAIM OR CLAIMS.

No terms, conditions, understanding, or agreements purporting to modify the terms of this warranty shall have any legal effect unless made in writing and signed by a corporate officer of the Seller.