

# TP-500

## Complete Weighing/Counting System

TP-500 SERIES



**TP-500-2005 or  
TP-500-2010**

Includes:  
\* cart with counting column  
\* 18" x 24" base  
\* TC-2005 or TC-2010



**TP-500SL**

Includes:  
\* cart with indicator column  
\* 18" x 24" base  
\* TI-500SL

This portable scale system includes a 1000lb 18" x 24" MSP weighing platform with a stainless steel weigh pan, a 36" column with built in handles, rear swivel casters & front fixed casters. The heavy duty cart protects the MSP platform scale by serving as a full perimeter guard. This simple function is vital in ensuring long life with low maintenance.

### TWO CONFIGURATIONS AVAILABLE:

**WEIGHING** - an NTEP approved TI-500SL stainless steel battery powered digital indicator is included.

**COUNTING** - either a TC-2005 or TC-2010 counting scale is included.



TRANSCCELL TECHNOLOGY, INC.

# TP-500

## STANDARD FEATURES & BENEFITS

### \* FULLY PORTABLE:

Can be positioned to weigh easily, or store when not in use. Each TP-500 is fitted with a convenient handle to provides quick and easy maneuverability for TOTAL PORTABILITY.

### \* SWIVEL CASTERS:

Two heavy duty swivel caster wheels are a standard feature and provide easier handling when moving heavy loads.

\* **TP-500SL** - includes TI-500 SL battery operated indicator

\* **TP-500-2005** - includes TC-2005 counting scale

\* **TP-500-2010** - includes TC-2010 counting scale

### \* RUGGED CARBON STEEL CONSTRUCTION:

Heavy duty Carbon steel construction for rugged environments. The sealed load cell is coated for surface protection and secured from overload by five mechanical stops.

## Specifications

### PLATFORM:

**Construction:** 24" L x 18" W x 5" H - Carbon Steel, with High Grade Epoxy Paint Finish

**Weigh Pan:** Type 304 Stainless Steel

**Weight sensors:** One Brick Load Cell (Load Cell 350 ohm)

**Load Feet:** 4 Hard Rubber

**Load Cell output:** 3mV/V

**Overload protection:** 150%

**Capacities:** 500 lb, 1000 lb

## Options

- **Cart only** & column for indicator
- **Cart only** & column for counting scale
- **Scale base only** 18" x 24" 500 or 1000 lb
- Stainless Steel roller ball top

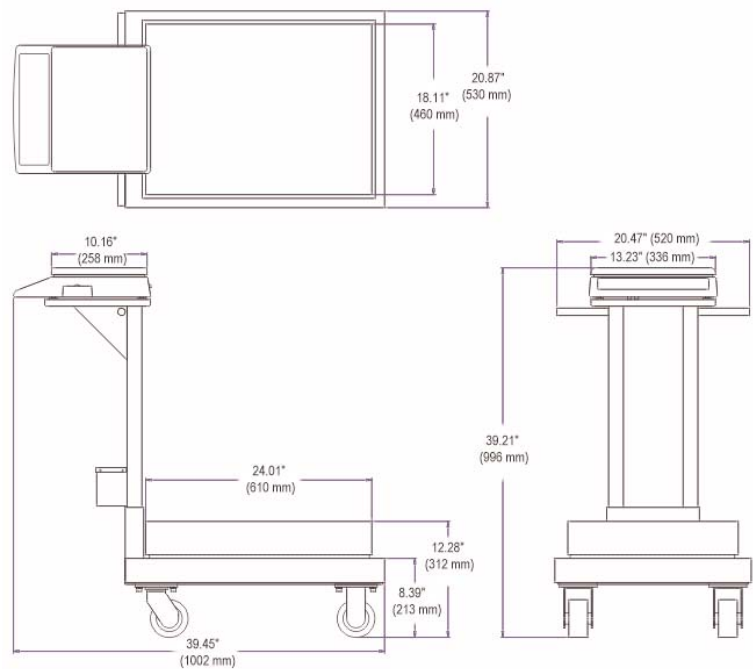
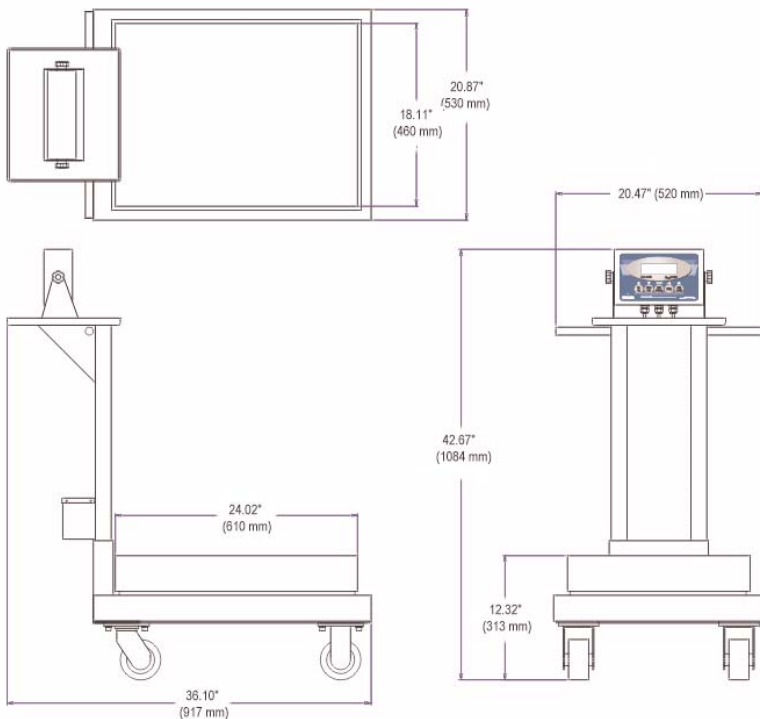

**YOUR AUTHORIZED TRANSCELL DEALER IS:**



REV 5-15-03

Specifications and features subject to change without notice.



**TRANSCELL TECHNOLOGY, INC.**

975 Deerfield Pkwy, Buffalo Grove, IL 60089

Tel (847) 419-9180 Fax (847) 419-1515

**(800) 503-9180**

www.transcell.net