



TRANSCCELL TECHNOLOGY, INC.

# ***TI-1500 Series***

## ***Digital Indicator***

### Setup / Operation Manual

Revision 1.6  
March 15, 2005

© 1999-2005 Transcell Technology, Inc.

Contents subject to change without notice.

Transcell Technology, Inc.  
975 Deerfield Parkway  
Buffalo Grove, IL 60089  
Tel (847) 419-9180  
Fax (847) 419-1515  
E-mail: [transcell@transcell.net](mailto:transcell@transcell.net)  
Web: [www.transcell.net](http://www.transcell.net)

### **NOTE**

This equipment has been tested and found to comply with the limits for a Class A digital device, pursuant to Part 15 of the FCC Rules. These limits are designed to provide reasonable protection against harmful interference when the equipment is operated in a commercial environment. This equipment generates, uses and can radiate radio frequency energy and, if not installed and used in accordance with the instructions manual, may cause harmful interference to radio communications. Operation of this equipment in a residential area is likely to cause harmful interference in which case the user will be required to correct the interference at his/her own expense.

# TABLE OF CONTENTS

|   | <u>Page</u> |
|---|-------------|
| Chapter 1: Introduction To The TI-1500 Series Indicators.....         | 1-1         |
| Chapter 2: Installation .....   | 2-1         |
| 2.1 ABS Enclosure (TI-1500) .....                                     | 2-1         |
| 2.1.1 Connecting the weigh platform.....                              | 2-1         |
| 2.1.2 Connecting the serial printer, remote display or computer ..... | 2-2         |
| 2.1.3 Connecting the power supply.....                                | 2-2         |
| 2.2 Stainless Steel Enclosure (TI-1520) .....                         | 2-3         |
| 2.2.1 Connecting the weigh platform.....                              | 2-4         |
| 2.2.2 Connecting the serial printer, remote display or computer ..... | 2-4         |
| 2.2.3 Connecting the power supply.....                                | 2-5         |
| Chapter 3: Configuration .....  | 3-1         |
| 3.1 Configuration Overview.....                                       | 3-1         |
| 3.2 Setup (“F”) Menu .....  | 3-1         |
| 3.2.1 Entering the Setup Menu – ABS Enclosure .....                   | 3-1         |
| 3.2.2 Entering the Setup Menu – Stainless Steel Enclosure .....       | 3-1         |
| 3.2.3 Navigating in the Setup Menu .....                              | 3-2         |
| 3.2.4 Notes on the Setup Menu .....                                   | 3-3         |
| 3.2.5 Exiting the Setup Menu – ABS Enclosure.....                     | 3-3         |
| 3.2.6 Exiting the Setup Menu – Stainless Steel Enclosure.....         | 3-3         |
| 3.3 User (“A”) Menu.....  | 3-3         |
| 3.3.1 Entering the User Menu .....                                    | 3-3         |
| 3.3.2 Navigating in the User Menu.....                                | 3-3         |
| 3.3.3 Notes on the User Menu .....                                    | 3-5         |
| 3.3.4 Exiting the User Menu.....                                      | 3-5         |
| Chapter 4: Setup Menu Descriptions and Procedures .....               | 4-1         |
| 4.1 Setup Menu Descriptions .....                                     | 4-1         |
| 4.2 Setup Menu Procedures .....                                       | 4-3         |
| 4.2.1 Custom Unit Multiplier (F11) .....                              | 4-3         |

|             |   |     |
|-------------|---|-----|
| Chapter 5:  | User Menu Descriptions and Procedures ..... | 5-1 |
| 5.1         | User Menu Descriptions.....                 | 5-1 |
| 5.2         | User Menu Procedures .....                  | 5-2 |
| 5.2.1       | ID Number Entry (A5).....                   | 5-2 |
| 5.2.2       | Line Feeds Entry (A6) .....                 | 5-3 |
| 5.2.3       | Time Entry (A10) .....                      | 5-3 |
| 5.2.4       | Date Entry (A13).....                       | 5-4 |
| Chapter 6:  | Calibration .....                           | 6-1 |
| 6.1         | Calibration Overview .....                  | 6-1 |
| 6.2         | Zero Calibration (F16).....                 | 6-1 |
| 6.3         | Span Calibration (F17) .....                | 6-1 |
| 6.4         | View Calibration Values (F18).....          | 6-2 |
| 6.5         | Key-in Zero Calibration Value (F19) .....   | 6-2 |
| 6.6         | Key-in Span Calibration Value (F20) .....   | 6-3 |
| Chapter 7:  | Operation.....                              | 7-1 |
| 7.1         | Display.....                                | 7-1 |
| 7.1.1       | Light Emitting Diode (LED) Display.....     | 7-1 |
| 7.2         | Keyboard .....                              | 7-2 |
| 7.2.1       | Function Keys.....                          | 7-2 |
| 7.3         | General Scale Operation.....                | 7-2 |
| 7.3.1       | Weighing an item.....                       | 7-2 |
| 7.3.2       | Taring an item .....                        | 7-2 |
| 7.3.3       | Piece Counting.....                         | 7-3 |
| Chapter 8:  | Legal for Trade Sealing.....                | 8-1 |
| 8.1         | ABS Enclosure .....                         | 8-1 |
| 8.2         | Stainless Steel Enclosure .....             | 8-1 |
| Appendix A: | Specifications .....                        | A-1 |
| Appendix B: | Serial Port Information.....                | B-1 |
| B.1         | COM1 Modes .....                            | B-1 |
| B.1.1       | Full Duplex Mode .....                      | B-1 |
| B.1.1.1     | Recognized Host Commands.....               | B-2 |
| B.1.2       | Print Ticket Mode .....                     | B-2 |
| B.2         | COM2 Mode .....                             | B-3 |
| B.2.1       | Simplex Mode.....                           | B-3 |

|   |     |
|---|-----|
| Appendix C: Determining Proper Span Gain (F2) ..... | C-1 |
| C.1 Span Gain Overview .....                        | C-1 |
| C.2 Setting the initial value for span gain .....   | C-1 |
| C.3 Viewing the internal counts .....               | C-1 |
| Appendix D: Displayed Error Codes .....             | D-1 |

## LIST OF FIGURES

|   |     |
|---|-----|
| 1-1 TI-1500 Front Panel .....   | 1-1 |
| 2-1 TI-1500 Rear Panel.....   | 2-1 |
| 2-2 Color Codes for Shielded Load Cell Cable .....                                    | 2-1 |
| 2-3 Pin Assignments for the Load Cell Port .....                                      | 2-1 |
| 2-4 Pin Assignments for the DSUB9 serial port connector .....                         | 2-2 |
| 2-5 TI-1520 Main Circuit Board Overview .....   | 2-3 |
| 2-5a TI-1520 Main Circuit Board Overview – newer units .....                          | 2-3 |
| 2-6 Connection Assignments for the Load Cell Terminal (J9) .....                      | 2-4 |
| 2-7 Connection Assignments for all serial communication Terminals .....               | 2-4 |
| 2-7a Connection Assignments for all serial communication Terminals – newer units..... | 2-4 |
| 3-1 Setup Menu Key Assignments.....   | 3-2 |
| 3-2 Setup Menu Chart.....   | 3-2 |
| 3-3 User Menu Key Assignments.....  | 3-4 |
| 3-4 User Menu Chart.....  | 3-4 |
| 4-1 Setup Menu Key Assignments.....   | 4-4 |
| 5-1 User Menu Key Assignments.....  | 5-2 |
| 6-1 Setup Menu Key Assignments.....   | 6-1 |
| 7-1 TI-1500/1520 LED Display Detail.....  | 7-1 |
| 7-2 Function Keys Layout .....  | 7-2 |
| 8-1 TI-1500 ABS Rear Panel .....  | 8-1 |
| B-1 Cable Diagram for Indicator to IBM PC .....                                       | B-1 |
| B-2 Consolidated Controls Demand Mode.....  | B-1 |
| B-3 Print Ticket .....  | B-3 |
| B-4 Cable Diagram for Indicator to Printer .....                                      | B-3 |
| B-5 Consolidated Controls Continuous Mode .....                                       | B-3 |

## LIST OF TABLES

|   |     |
|---|-----|
| 1-1 TI-1500 Series Product Matrix .....                       | 1-1 |
| 4-1 Invalid Setup Selections for commercial applications..... | 4-3 |
| 6-1 Calibration Value Table.....                              | 6-2 |
| 7-1 TI-1500 Series Annunciator Definitions .....              | 7-1 |
| C-1 Minimum Recommended Span Gain Table.....                  | C-2 |

## CHAPTER 1: INTRODUCTION TO THE TI-1500 SERIES DIGITAL INDICATORS

The TI-1500 Series Digital Indicator is a general purpose, industrial grade weight indicator featuring piece counting operation and a custom unit. Four models are currently available, distinguishable by display type and enclosure type. Table 1-1 shows the TI-1500 series product matrix. All models operate identically, can readout up to 50,000 display divisions and can supply enough current for up to 8-350 $\Omega$  load cells. All setup parameters may be entered via the front panel keys, including calibration.

If your Model TI-1500 Series Digital Indicator is part of a complete floor scale or has been installed for you, you may skip to Chapter 7 for operating instructions. Prior to using the indicator, please read this chapter carefully and completely. Store the manual in a safe and convenient place so it will be available if you have questions concerning the operation of the scale.

If you are an installer, the indicator's installation and wiring instructions are found in Chapter 2. The indicator contains two main setup menus: The Setup ("F") menu, which configures the indicator to your weigh platform and the User ("A") menu, which configures the serial communication port and enables some user options. Chapter 3 gives an overview and explains how to use the five front panel keys to maneuver and save settings in both menus. Chapters 4 and 5 explain the Setup and User Menu options, respectively. Chapter 6 covers system calibration. Prior to installing the indicator, please read this manual carefully and completely. Store the manual in a safe and convenient place so it will be available if you have questions concerning the setup and operation of the scale.

| MODEL   | DISPLAY TYPE                          | ENCLOSURE TYPE                 |
|---------|---------------------------------------|--------------------------------|
| TI-1500 | LED (light emitting diode), 1.0" tall | ABS, NEMA 12 rated             |
| TI-1520 | LED (light emitting diode), 1.0" tall | Stainless Steel, NEMA 4X rated |

TABLE 1-1: TI-1500 Series Product Matrix

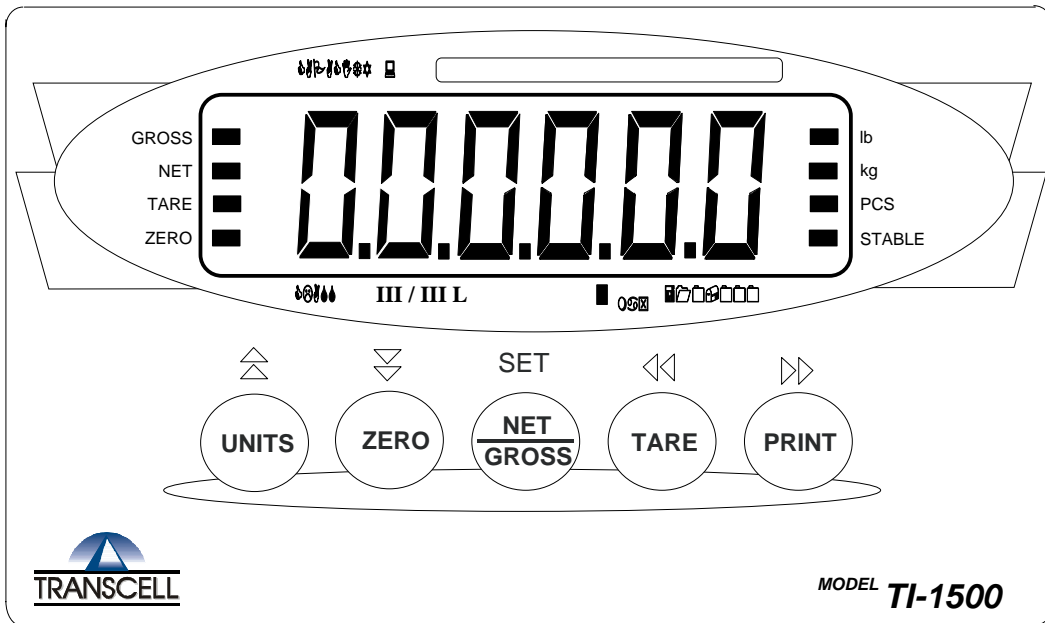
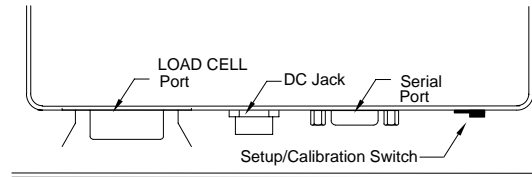

FIGURE 1-1: TI-1500 Front Panel

## CHAPTER 2: INSTALLATION

### 2.1 ABS ENCLOSURE (TI-1500)

For indicators contained in the standard ABS enclosure, the rear panel contains all connectors necessary to make the appropriate connections to the weigh platform, printer, remote display and power supply.



**Figure 2-1: TI-1500 ABS Enclosure Rear Panel**

#### 2.1.1 CONNECTING THE WEIGH PLATFORM

The indicators mounted in an ABS enclosure ship with a 15 ft shielded load cell cable for connection to weigh platform's load cell(s) or junction box.

1. Plug the cable's 14-pin Centronics-type connector into the load cell port on the rear panel of the indicator.
2. Wire the bare wires and shield to the weigh platform's load cell(s) or junction box using the color codes shown in Figure 2-2.

| Color | Wire Name   |
|-------|-------------|
| RED   | +Excitation |
| BLK   | -Excitation |
| GRN   | +Signal     |
| WHT   | -Signal     |

**Figure 2-2: Color Codes for Shielded Load Cell Cable**

3. If you do not wish to use the shielded load cell cable, you may use own, following the pin assignments shown in Figure 2-3. (A 14-pin Male Centronics-type connector is required).

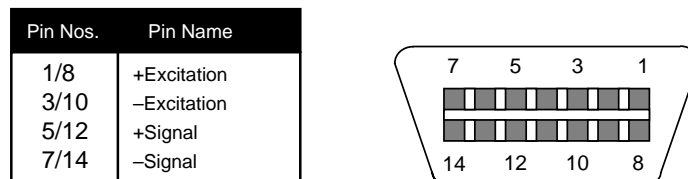

**Figure 2-3: Pin assignments for the Load Cell Port**



### 2.1.2 CONNECTING THE SERIAL PRINTER, REMOTE DISPLAY OR COMPUTER

The TI-1500 series indicator comes standard with two serial ports, designated COM1 and COM2. COM1 is a full duplex, RS-232 port designed for connection to either a PC or a serial printer. COM2 is a simplex, RS-232 / Passive 20 mA Current Loop port designed for connection to a remote display.

For indicators housed in an ABS enclosure, both COM ports are wired to one physical connector, a DSUB9 female. As a result, you must use a “Y” interface cable (not included) to gain access to COM2. Figure 2-4 shows the serial port pinout. Refer to Appendix B for some suggested cable diagrams. (A 9-pin pin Male D-type connector is required).

1. Plug the serial printer or computer communication cable (not included) directly into the DSUB9 serial port connector or into the port labeled COM1 on the “Y” interface cable.
2. Plug the remote display cable (not included) directly into the port labeled COM2 on the “Y” interface cable.

| Pin No. | Pin Name      | Port | Signal Level |
|---------|---------------|------|--------------|
| 2       | Receive Data  | COM1 | RS-232       |
| 3       | Transmit Data | COM1 | RS-232       |
| 4       | Transmit Data | COM2 | RS-232       |
| 5       | Signal Ground | Both | RS-232       |
| 7       | CL +          | COM2 | 20 mA        |
| 8       | CL -          | COM2 | 20 mA        |

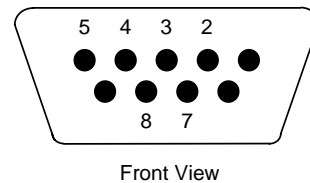

**Figure 2-4: Pin assignments for the DSUB9 serial port connector**

### 2.1.3 CONNECTING THE POWER SUPPLY

1. The indicator ships standard with an internal AC to DC adapter. Simply plug the AC line cord into a standard wall outlet.
2. If the indicator was shipped with the optional external AC adapter, simply plug the AC adapter into the indicator’s DC Power Jack first, and then plug into a standard wall outlet. ***Make sure that the AC voltage appearing at the wall outlet matches the input voltage marked on the AC adapter.***

## 2.2 STAINLESS STEEL ENCLOSURE (TI-1520)

For indicators contained in a stainless steel enclosure, the rear cover must first be removed to make the appropriate connections to the weigh platform, printer, remote display and power supply. To remove the rear cover, simply remove the screws that secure it to the enclosure and set aside.

**NOTE:** The rear cover must remain off to access the Setup Menu and calibration procedures.

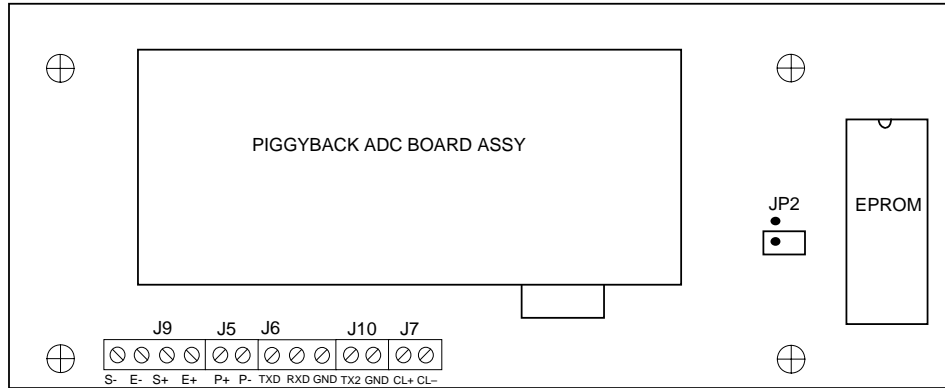

Figure 2-5: TI-1520 Main Circuit Board Overview – older units

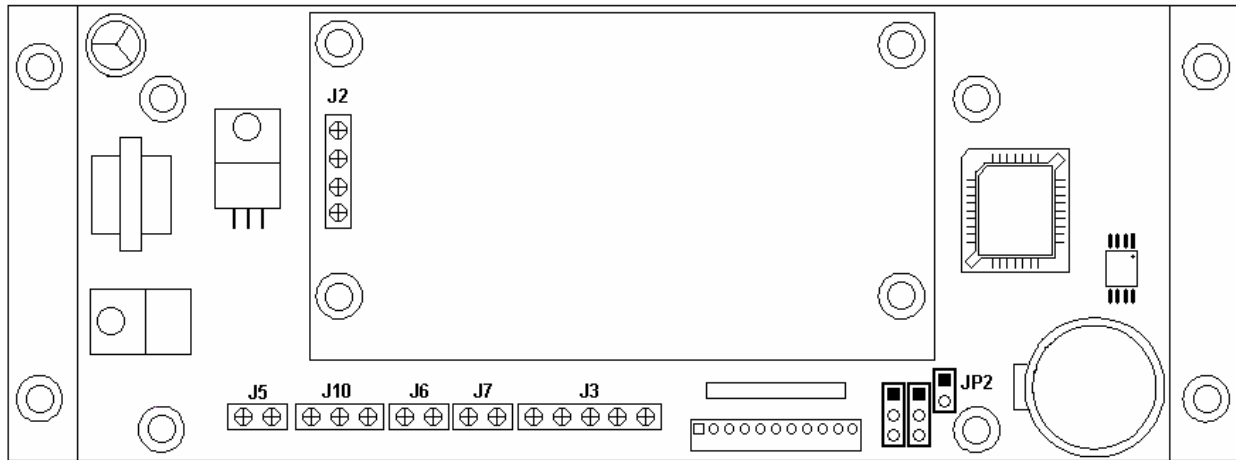

Figure 2-5a: TI-1520 Main Circuit Board Overview – newer units

### 2.2.1 CONNECTING THE WEIGH PLATFORM

1. Connect your shielded load cell cable (not included) to the appropriate terminal on the main board. Connection assignments for the Load Cell Terminals are shown in Figure 2-6.

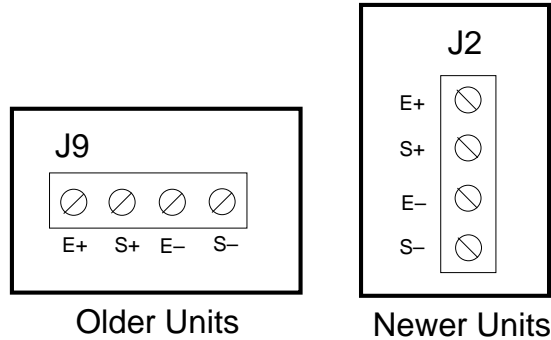

Figure 2-6: Connection assignments for the Load Cell Terminal

### 2.2.2 CONNECTING THE SERIAL PRINTER, REMOTE DISPLAY OR COMPUTER

The TI-1500 series indicator comes standard with two serial ports, designated COM1 and COM2. COM1 is a full duplex, RS-232 port designed for connection to either a PC or a serial printer. COM2 is a simplex, RS-232 / Passive 20 mA Current Loop port designed for connection to a remote display.

For indicators housed in a Stainless Steel enclosure, COM1 is realized in J6 / J10 (older / newer) while COM2 is realized in both J10 / J6 (older / newer) and J7. J10 / J6 is an RS-232 port and J7 is a CL port. Connection assignments for all serial communication terminals are shown in Figure 2-7 and Figure 2-7a.

1. Connect your serial printer or computer communication cable (not included) to terminal J6 / J10 on the main board.
2. Connect your remote display communication cable (not included) to terminal J10 / J6 or J7 on the main board

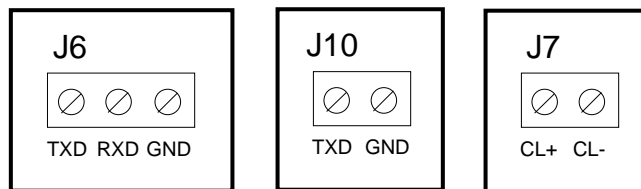

Figure 2-7: Connection assignments for all serial communication terminals – older units

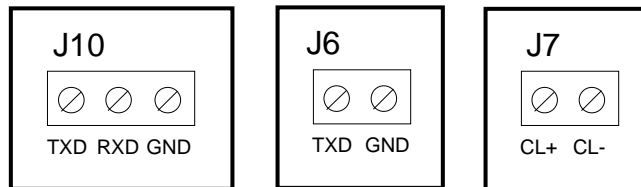

Figure 2-7a: Connection assignments for all serial communication terminals – newer units

### 2.2.3 CONNECTING THE POWER SUPPLY

1. The indicator ships standard with an internal AC to DC adapter. Simply plug the AC line cord into a standard wall outlet.
2. If the indicator was shipped with the optional external AC adapter, simply plug the AC adapter into the indicator's DC Power Jack first, and then plug into a standard wall outlet. ***Make sure that the AC voltage appearing at the wall outlet matches the input voltage marked on the AC adapter.***

## CHAPTER 3: CONFIGURATION

### 3.1 CONFIGURATION OVERVIEW

The indicator contains two main setup menus: The Setup ("F") menu which configures the indicator to your weigh platform and the User ("A") menu which configures the serial communication port and enables some user options. The Setup and User menus consist of several menu selections, each with its own sub-menu of choices.

To set up the indicator, you must first enter the appropriate menu mode. Once there, four of the front panel keys become directional navigators to move around in the menus, and one key is used to save or SET the selections.

### 3.2 SETUP ("F") MENU

#### 3.2.1 ENTERING THE SETUP MENU – ABS ENCLOSURE

1. Power off the indicator by unplugging the power source.
2. On the back cover, move the Setup/Calibration Switch to the opposite position.
3. Power on the indicator by plugging in the power source. The indicator shows " F 1" to indicate that you are in Setup Menu mode.

**Note:** Access to the Setup/Calibration Switch is inhibited if the indicator has been sealed for commercial use. For more information, please refer to Chapter 8.

#### 3.2.2 ENTERING THE SETUP MENU – STAINLESS STEEL ENCLOSURE

1. Power off the indicator.
2. Locate the slide switch on the rear cover and move it to the right.

**NOTE:** A metal plate held on by two drilled-head screws may conceal the slide switch.

3. Power on the indicator. The indicator shows " F 1" to indicate that you are in Setup Menu mode.

**Note 1:** Access to the back cover is inhibited if the indicator has been sealed for commercial use. For more information, please refer to Chapter 8.

**Note 2:** If your indicator is an older model and does not have the slide switch on the rear cover, follow these instructions instead:

#### TI-1520

1. Remove the rear cover and locate jumper JP2.

2. Position the shunt block as shown at right.  JP2

**Note:** On certain units, the shunt block position will be exactly the opposite.

3. Power on the indicator. The indicator shows " F 1" to indicate that you are in Setup Menu mode.

### 3.2.3 NAVIGATING IN THE SETUP MENU

Use the directional keys shown in Figure 3-1 to move around in the Setup Menu Chart shown in Figure 3-2 on the following page.

1. To move to a new "F" heading, use the TARE (left) or PRINT (right) key to move right or left in the Setup Menu Chart.
2. To move to the selection level, press the ZERO (down) key once. The current saved selection is shown.
3. To view the available selections for the current "F" heading, use the TARE (left) or PRINT (right) key to move through the selection field.
4. To save a new selection, press the NET/GROSS (Set) key. To exit without saving, press the UNITS (up) key to return to the current "F" heading.
5. Repeat Steps 1 through 4 until the Setup Menu is programmed.

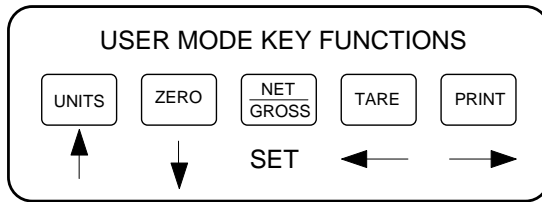

**Figure 3-1: Setup Menu Key Assignments**

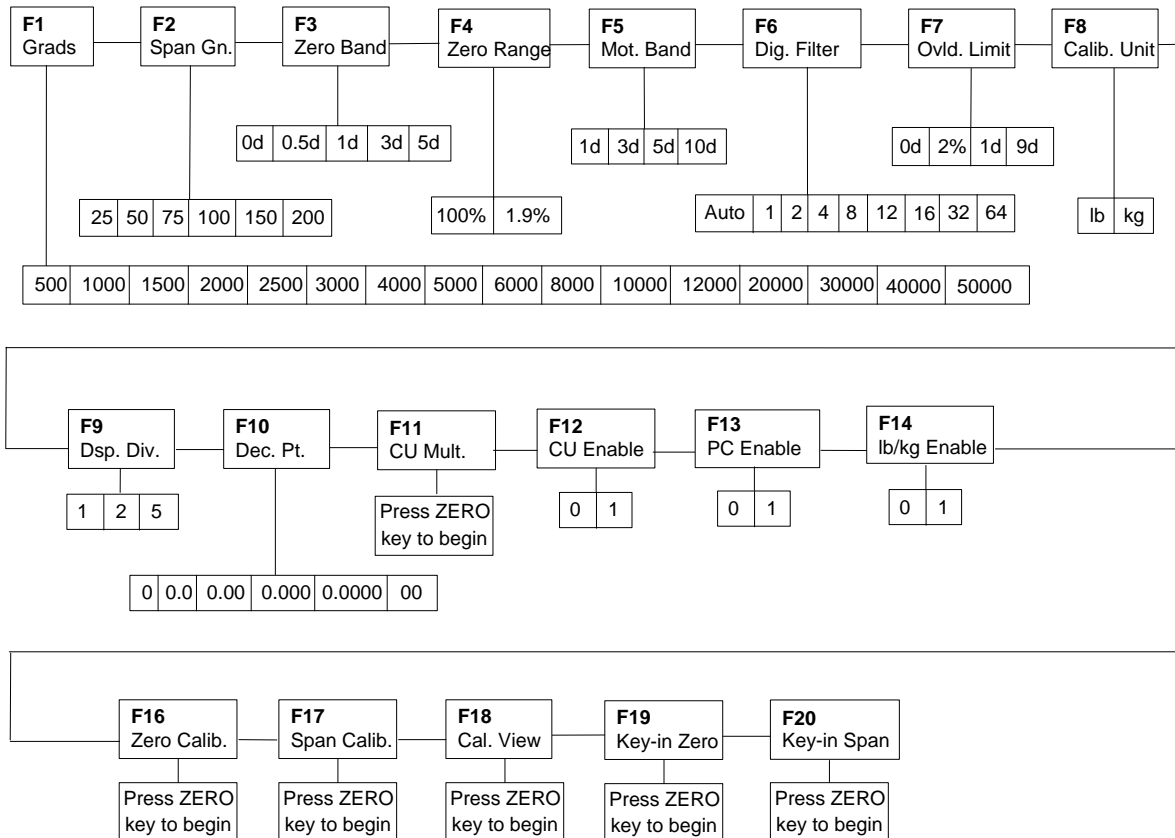

**Figure 3-2: Setup Menu Chart**

### 3.2.4 NOTES ON THE SETUP MENU

1. There is an **F21** sub-menu present that is for **FACTORY USE ONLY!**
2. Detailed descriptions of the setup menu parameters can be found in Chapter 4 of this manual.
3. The User (“A”) menu sub-menus appear when scrolling left or right from the “F” menu.

### 3.2.5 EXITING THE SETUP MENU – ABS ENCLOSURE

1. Power off the indicator by unplugging the power source.
2. On the back cover, move the Setup/Calibration Switch back to its original position.
3. Power on the indicator by plugging in the power source. The display will go through a digit check, then settle into Normal Operating mode. All front panel keys will now return to their normal mode of operation.

### 3.2.6 EXITING THE SETUP MENU – STAINLESS STEEL ENCLOSURE

1. Power off the indicator.
2. Move the slide switch on the rear cover back to the left.
3. Power on the indicator. The display will go through a digit check, then settle into Normal Operating mode. All front panel keys will now return to their normal mode of operation.

**Note:** If your indicator is an older model and does not have the slide switch on the rear cover, follow these instructions instead:

#### TI-1520

1. Remove the rear cover and locate jumper JP2.
  2. Position the shunt block as shown at right.  JP2
- Note:** On certain units, the shunt block position will be exactly the opposite.
3. Power on the indicator. The display will go through a digit check, then settle into Normal Operating mode. All front panel keys will now return to their normal mode of operation.

## 3.3 USER (“A”) MENU

### 3.3.1 ENTERING THE USER MENU

1. Enter the Setup (“F”) menu by following the directions in Section 3.2.1 or 3.2.2.
2. Use the right or left directional keys shown in Figure 3-3 to move right or left in the Setup (“F”) menu until the indicator shows “A 1”.

### 3.3.2 NAVIGATING IN THE USER MENU

Use the directional keys shown in Figure 3-3 to move around in the User Menu Chart shown in Figure 3-4 on the following page.

1. To move to a new “A” heading, use the TARE (left) or PRINT (right) key to move right or left in the User Menu Chart.
2. To move to the selection level, press the ZERO (down) key once. The current saved selection is shown.

3. To view the available selections for the current "A" heading, use the TARE (left) or PRINT (right) key to move through the selection field.
4. To save a new selection, press the NET/GROSS (Set) key. To exit without saving, press the UNITS (up) key to return to the current "A" heading.
5. Repeat Steps 2 through 5 until the User Menu is programmed.

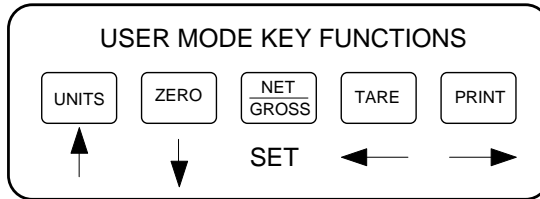

**Figure 3-3: User Menu Key Assignments**

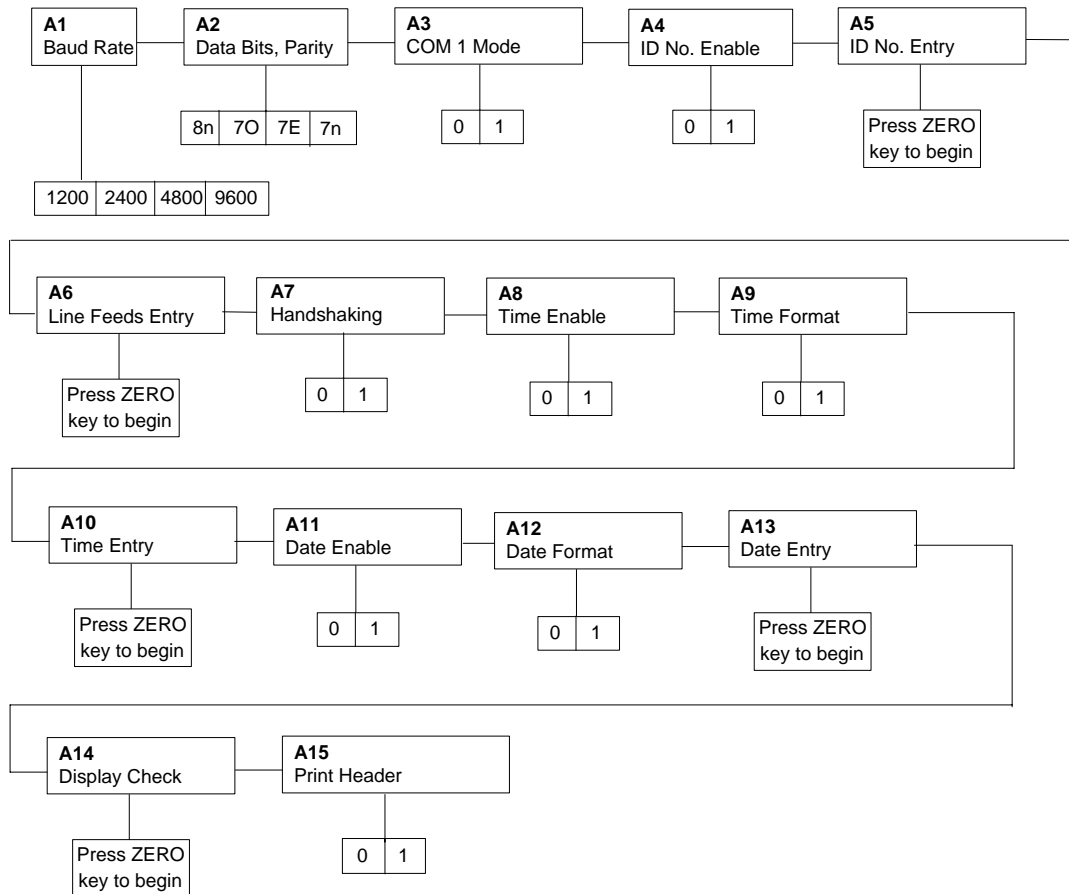

**Figure 3-4: User Menu Chart**



### **3.3.3 NOTES ON THE USER MENU**

1. Sub-menus A8 through A13 will not appear on older units unless you have the Time and Date option.
2. Detailed descriptions of the user menu parameters can be found in Chapter 5 of this manual.

### **3.3.4 EXITING THE USER MENU**

1. Exit the User ("A") menu by following the directions in Section 3.2.5 or 3.2.6. The display will go through a digit check, then settle into Normal Operating mode. All front panel keys will now return to their normal mode of operation.

## CHAPTER 4: SETUP MENU DESCRIPTIONS AND PROCEDURES

### 4.1 SETUP MENU DESCRIPTIONS

This section provides more detailed descriptions of the selections found in the Setup Menu Chart. Factory-set defaults are shown in bold with a checkmark (✓).

Table 4-1 shows the selections that are not allowed for “Legal-for-Trade” applications:

| NAME/CODE                    | DESCRIPTION  | CODE/VALUE  |
|------------------------------|--|---|
| <b>F1</b><br>Graduations     | Specifies number of full-scale graduations. Value should be consistent with legal requirements and environmental limits on the useful system resolution.   | 500 1,000<br>1,500 2,000<br>2,500 3,000<br>4,000 5,000<br>6,000 8,000<br><b>10,000</b> ✓ 12,000<br>20,000 30,000<br>40,000 50,000 |
| <b>F2</b><br>Span Gain       | Span Gain is related to A/D integration time. The larger the span gain, the higher the internal resolution, but the slower the update speed. Note that the scale must be re-calibrated whenever this parameter is altered. See Appendix C for more information.                                | 25 50<br>75 <b>100</b> ✓<br>150 200   |
| <b>F3</b><br>Zero Track Band | Selects the range within which the scale will automatically zero. Note that the scale must be in standstill to automatically zero. Selections are in Display Divisions.  | 0d<br><b>0.5d</b> ✓<br>1d<br>3d<br>5d   |
| <b>F4</b><br>Zero Range      | Selects the range within which the scale may be zeroed. Note that the indicator must be in standstill to zero the scale.   | <b>100%</b> ✓<br>1.9%   |
| <b>F5</b><br>Motion Band     | Sets the level at which motion is detected by comparing the present display update with the previous one. If motion is not detected for two seconds or more, scale is in standstill and can process a Print or Zero command. Maximum value varies depending on local regulations.              | <b>1d</b> ✓<br>3d<br>5d<br>10d  |
| <b>F6</b><br>Digital Filter  | Averages weight readings to produce higher stability. The higher the filter number, the greater the stability but the slower the response time. Choose 8 or 12 unless a very fast response is needed. Use the “Auto” setting to automatically determine the filter length as you are weighing. | <b>Auto</b> ✓<br>1 2<br>4 8<br>12 16<br>32  |
| <b>F7</b><br>Overload Limit  | Selects the desired formula which determines the point at which the indicator shows overload. All selections are based on the primary unit selected in F8.<br><br>"FS" = Full scale in primary units.  | FS<br><b>FS + 2%</b> ✓<br>FS + 1d<br>FS + 9d  |
| <b>F8</b><br>Calib. Unit     | Selects the primary base unit to be used in the calibration process. Also the default unit for normal operation.<br>"1" = primary unit is lb. "2" = primary unit is in kg.   | <b>1</b> ✓<br>2   |

| NAME/CODE                             | DESCRIPTION   | CODE/VALUE                                    |
|---------------------------------------|---|---|
| <b>F9</b><br>Display Divisions        | Determines the desired weight increments. Value should be consistent with legal requirements.   | 1√<br>2<br>5                                  |
| <b>F10</b><br>Decimal Pt.             | Determines location of the decimal point.   | 0√      0.0<br>0.00    0.000<br>0.0000   00   |
| <b>F11</b><br>Custom Unit Multiplier  | Actuates the function that allows you to enter a multiplier for the custom unit. Scrolling down with the <b>ZERO</b> key one level begins the procedure.  | Press <b>ZERO</b> key to begin sequence<br>1√ |
| <b>F12</b><br>Custom Unit Enable      | Used to enable or disable the custom unit whenever the UNITS key is pressed. This feature must be disabled for commercial applications.<br>"0" = Disable custom unit                      "1" = Enable custom unit  | 0<br>1√                                       |
| <b>F13</b><br>Piece Count Enable      | Used to enable or disable the piece count feature. This feature must be disabled for commercial applications.<br>"0" = Disable piece count                      "1" = Enable piece count  | 0<br>1√                                       |
| <b>F14</b><br>lb/kg Conversion Enable | Used to enable or disable the lb to kg conversion whenever the UNITS key is pressed.<br>"0" = Disable conversion                      "1" = Enable conversion   | 0<br>1√                                       |
| <b>F16</b><br>Zero Calibration        | Places indicator into the zero calibration routine. Scrolling down with the <b>ZERO</b> key one level begins the procedure.   | Press <b>ZERO</b> key to begin sequence       |
| <b>F17</b><br>Span Calibration        | Places indicator into the span calibration routine. Scrolling down with the <b>ZERO</b> key one level begins the procedure.   | Press <b>ZERO</b> key to begin sequence       |
| <b>F18</b><br>View Calibration        | Actuates the function that allows you to view both the zero and span calibration value. The values displayed in this function are valid only after Calibration (F16 & F17) has been successfully completed. Scrolling down with the <b>ZERO</b> key one level begins the procedure. | Press <b>ZERO</b> key to begin sequence       |
| <b>F19</b><br>Key-in Zero             | Allows you to key-in known zero calibration value in case of memory loss in the field. Scrolling down with the <b>ZERO</b> key one level begins the procedure.  | Press <b>ZERO</b> key to begin sequence       |
| <b>F20</b><br>Key-in Span             | Allows you to key-in a known span calibration value in case of memory loss in the field. Scrolling down with the <b>ZERO</b> key one level begins the procedure.  | Press <b>ZERO</b> key to begin sequence       |
| <b>F21</b><br>Factory Reset           | This sub-menu will reset all parameters in the "F" and "A" menu to the default settings. USE WITH CAUTION!  | Press the <b>ZERO</b> key twice to execute.   |

| SUB-MENU | TITLE                      | SELECTIONS                                     |
|----------|----------------------------|--|
| F1       | Graduations                | 12,000<br>20,000<br>30,000<br>40,000<br>50,000 |
| F3       | Zero Tracking Band (SAZSM) | 0d<br>5d                                       |
| F4       | Zero Reset Range           | 100% (Canada Only)                             |
| F5       | Motion Band                | 3d<br>5d<br>10d                                |
| F6       | Digital Filter             | 1<br>2<br>4                                    |
| F12      | Custom Unit                | 1  |
| F13      | Piece Count                | 1  |

**Table 4-1: Invalid Setup Menu selections for commercial applications**

## 4.2 SETUP MENU PROCEDURES

This section provides instructions for all of the Setup Menu procedures with the exception of the Calibration procedures (F16 through F20) which can be found in Chapter 6.

### 4.2.1 CUSTOM UNIT MULTIPLIER (F11)

The custom unit multiplier is the conversion factor that you would multiply the calibration unit by in order to obtain the custom unit of weight. For example, if your scale is calibrated in pounds and you wish to display weight in ounces, you would enter in a multiplier value of 16.0. The indicator automatically determines the proper display increment for your custom unit.

1. While in the Setup mode, scroll to "**F 11**", then scroll down once using the **ZERO** key to enter the custom unit multiplier menu.
2. The display will momentarily show "**C U**" for the custom unit, followed by the current value for the custom unit multiplier with the decimal point.
3. Use the left or right directional keys (shown in Figure 4-1 below) to move the decimal point position to the correct position. Pressing the PRINT key or the TARE key will change the position of the decimal point.
4. After setting the correct decimal point position, press the NET/GROSS key to save it.

5. The display will momentarily show "**SET**", followed by a value with one flashing digit. This value will be the current multiplier value with the decimal point position programmed above.
6. Use the four directional keys (shown in Figure 4-1 below) to adjust the displayed value to the actual custom unit multiplier value. Increase the flashing digit by pressing the **UNITS** key. Decrease the flashing digit by pressing the **ZERO** key. Pressing the **PRINT** key or the **TARE** key will change the position of the flashing digit.

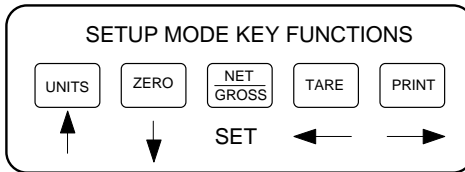

**Figure 4-1: Setup Menu Key Assignments**

7. After setting the exact value, press the **NET/GROSS** key to save the custom unit multiplier value. The display will show "**EndCU**" momentarily, then revert back up to F11.

## CHAPTER 5: USER MENU DESCRIPTIONS AND PROCEDURES

### 5.1 USER MENU DESCRIPTIONS

This section provides more detailed descriptions of the selections found in the User Menu Chart. Factory-set defaults are shown in bold with a checkmark (✓).

| NAME/CODE                         | DESCRIPTION  | CODE/VALUE  |
|-----------------------------------|--|---|
| <b>A1</b><br>Baud Rate            | Selects the baud rate for data transmission through both serial ports (COM1 and COM2).   | 1200    2400<br>4800 <b>9600</b> ✓ <sup>1</sup><br>19200  |
| <b>A2</b><br>Data Bits and Parity | Selects the number of data bits and parity of serial transmission.<br>"8n" = 8 data bits with no parity bit and one stop bit<br>"7O" = 7 data bits with odd parity bit and one stop bit<br>"7E" = 7 data bits with even parity bit and one stop bit<br>"7n" = 7 data bits with no parity bit and two stop bits | <b>8n</b> ✓<br>7O<br>7E<br>7n                             |
| <b>A3</b><br>COM1 Mode            | Selects the mode of the COM1 serial port: Refer to Appendix B for more information.<br>"0" = Full Duplex Mode<br>"1" = Print Ticket Mode   | 0<br><b>1</b> ✓ <sup>2</sup>                              |
| <b>A4</b><br>ID No. Enable        | Allows the ID number to be disabled in the Print Ticket mode. Valid only when <b>A3</b> is set to "1".<br>"0" = Disable the ID No.                      "1" = Enable the ID No.  | <b>0</b> ✓<br>1   |
| <b>A5</b><br>ID No. Entry         | Actuates the function that allows entry of a new ID No. Valid only when <b>A3</b> is set to "1". Pressing the <b>ZERO</b> key to scroll down one level begins the sequence.  | 0 - 199999 (1510)<br>0 - 999999 (1500)<br><b>123456</b> ✓ |
| <b>A6</b><br>No. of Line Feeds    | Actuates the function that allows entry of the desired number of line feeds to be printed in Print Ticket Mode. Valid only when <b>A3</b> is set to "1". Pressing the <b>ZERO</b> key to scroll down one level begins the sequence.  | 0 - 99<br><b>8</b> ✓ <sup>3</sup>                         |
| <b>A7</b><br>Handshaking Enable   | Enables hardware handshaking for Print Ticket Mode. Valid only when <b>A3</b> is set to "1".<br>"0" = Disable Handshaking                      "1" = Enable Handshaking  | <b>0</b> ✓<br>1   |
| <b>A8</b><br>Time Enable          | Allows the time to be disabled in the Print Ticket mode. Valid only when <b>A3</b> is set to "1".<br>"0" = Disable the time printout                      "1" = Enable the time printout   | <b>0</b> ✓<br>1   |
| <b>A9</b><br>Time Format          | Selects the printed format for current time. Valid only when <b>A3</b> is set to "1" and indicator contains Time and Date option.<br>"0" = AM/PM    "1" = 24 Hr  | <b>0</b> ✓<br>1   |
| <b>A10</b><br>Time Entry          | Actuates the function that allows entry of the current time. Valid only for indicators containing the Time and Date option. Pressing the <b>ZERO</b> key to scroll down one level begins the test sequence.  | Press <b>ZERO</b> key to begin sequence                   |

<sup>1</sup> Newer units only. All others default to 2400.

<sup>2</sup> Newer units only. All others default to 0.

<sup>3</sup> Newer units only. All others default to 5.

| NAME/CODE                               | DESCRIPTION   | CODE/VALUE                              |
|---|---|---|
| <b>A11</b><br>Date Enable               | Allows the date to be disabled in the Print Ticket mode. Valid only when <b>A3</b> is set to "1".<br>"0" = Disable the date printout                      "1" = Enable the date printout                        | 0√<br>1                                 |
| <b>A12</b><br>Date Format               | Selects the printed format for current date. Valid only when <b>A3</b> is set to "1" and indicator contains Time and Date option.<br>"0" = mm/dd/yy    "1" = dd/mm/yy | 0√<br>1                                 |
| <b>A13</b><br>Date Entry                | Actuates the function that allows entry of the current date. Valid only for indicators containing the Time and Date option. Pressing the <b>ZERO</b> key to scroll down one level begins the test sequence.     | Press <b>ZERO</b> key to begin sequence |
| <b>A14</b><br>Display Check             | Actuates the function that illuminates all digit segments, decimal points, and LCD annunciators in a test sequence. Pressing the <b>ZERO</b> key to scroll down one level begins the test sequence.             | Press <b>ZERO</b> key to begin sequence |
| <b>A15</b> <sup>4</sup><br>Print Header | Tells MP-20 printer to print the header information. Valid only when <b>A3</b> is set to "1".<br>"0" = Do NOT Print Header                      "1" = Print Header  | 0√<br>1                                 |

## 5.2 USER MENU PROCEDURES

This section provides instructions for all of the User Menu procedures.

### 5.2.1 ID Number Entry (A5)

1. While in the User Menu mode, scroll to "**A 5**", then scroll down once using the ZERO key to enter the ID Number menu.
2. The display will momentarily show "**ID NO**", followed by a value with one flashing digit. This value will be the current ID number value.
3. Use the four directional keys (shown in Figure 5-1 below) to adjust the displayed value to the actual ID Number value. Increase the flashing digit by pressing the UNITS key. Decrease the flashing digit by pressing the ZERO key. Pressing the PRINT key or the TARE key will change the position of the flashing digit.

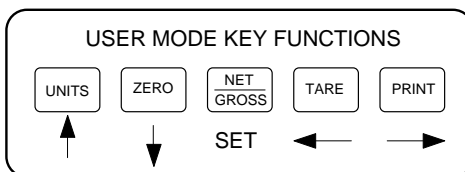

**Figure 5-1: User Menu Key Assignments**

4. After setting the exact value, press the NET/GROSS key to save the ID Number value. The display will show "**SET**" momentarily, then revert back up to A5.

<sup>4</sup> Will not appear on older units.

### 5.2.2 LF (Line Feeds) Number Entry (A6)

1. While in the User Menu mode, scroll to "**A 6**", then scroll down once using the ZERO key to enter the Line Feeds menu.
2. The display will momentarily show "**LF**", followed by the current line feeds value.
3. Use the four directional keys (shown in Figure 5-1 above) to adjust the displayed value to the actual line feeds value. Increase the flashing digit by pressing the UNITS key. Decrease the flashing digit by pressing the ZERO key. Pressing the PRINT key or the TARE key will change the position of the flashing digit.
4. After setting the exact value, press the NET/GROSS key to save the line feeds value. The display will show "**SET**" momentarily, then revert back up to A6.

### 5.2.3 Time Entry (A10)

Your indicator will keep track of the current time for you, which can then be printed on the print ticket. Use this procedure to set the current time, which must be set in military (24-hr) format. For example, for 9:00 AM, you would enter 900. For 5:00 PM, you would enter 1700.

NOTE: This menu will not appear on older units unless you have the time/date option.

1. While in the User Menu mode, scroll to "**A 10**", then scroll down once using the ZERO key to enter the time entry menu.
2. The display will momentarily show "**ENT TI**", followed by a value with one flashing digit. This value will be the current time in military (24-hr) format.
3. Use the four directional keys (shown in Figure 5-1 above) to adjust the displayed value to the actual time value. Increase the flashing digit by pressing the UNITS key. Decrease the flashing digit by pressing the ZERO key. Pressing the PRINT key or the TARE key will change the position of the flashing digit.
4. After setting the exact value, press the NET/GROSS key to save the time value. The display will show "**End TI**" momentarily, then revert back up to A10.



#### 5.2.4 Date Entry (A13)

Your indicator will keep track of the current date for you, which can then be printed on the print ticket. Use this procedure to set the current date, which must be set in mm/dd/yy format. For example, for January 7, 1998, you would enter 010798. For November 30, 1998 you would enter 113098.

NOTE: This menu will not appear on older units unless you have the time/date option.

1. While in the User Menu mode, scroll to "**A 13**", then scroll down once using the ZERO key to enter the date entry menu.
2. The display will momentarily show "**ENT DT**", followed by a value with one flashing digit. This value will be the current date in mm/dd/yy format.
3. Use the four directional keys (shown in Figure 5-1 above) to adjust the displayed value to the actual date value. Increase the flashing digit by pressing the UNITS key. Decrease the flashing digit by pressing the ZERO key. Pressing the PRINT key or the TARE key will change the position of the flashing digit.
4. After setting the exact value, press the NET/GROSS key to save the date value. The display will show "**End DT**" momentarily, then revert back up to A13.

## CHAPTER 6: CALIBRATION

### 6.1 CALIBRATION OVERVIEW

The indicator is calibrated by following the procedures embedded in F16 (Zero) and F17 (Span) of the Setup Menu. Each procedure enters a value into the indicator's non-volatile memory - F16 the zero value (deadweight) and F17 the span value (test weight). The minimum test weight that can be used is 1% of full-scale capacity. After the two calibration procedures are executed successfully, you should record both calibration values in Table 6-1 using the F18 View procedure.

In the unlikely event that either value is lost while in the field, the setup menu makes provisions for re-entering these values via F19 and F20, thus eliminating the need for re-calibration with test weights.

**NOTE:** This chapter assumes that the indicator is in Setup ("F") Menu mode. If the indicator is not in Setup Menu mode, refer to Chapter 3 for instructions.

### 6.2 ZERO CALIBRATION (F16)

1. While in the Setup mode, scroll to "**F 16**", then scroll down once using the ZERO key to enter zero calibration menu. The display will momentarily show "**C 0**" followed by a value. This value is the internal A/D count and can prove useful when trying to troubleshoot setup problems.
2. After making sure that there are no test weights on the platform, press the ZERO key again to zero out the displayed value.
3. Press the NET/GROSS key to save the zero point value. The display will show "**EndC0**" momentarily, then revert back up to F16. At this time, proceed to the F17 span calibration to complete indicator calibration.

### 6.3 SPAN CALIBRATION (F17)

1. While in the Setup mode, scroll to "**F 17**", then scroll down once using the ZERO key to enter span calibration menu.
2. The display will momentarily show "**C 1**" for the span calibration, followed by a value with one flashing digit. This value will be zero with the Decimal Point parameter selected in F10. Place the test weight on the weighing mechanism.
3. Use the four directional keys (shown in Figure 6-1 below) to adjust the displayed value to the actual test weight value. Increase the flashing digit by pressing the UNITS key. Decrease the flashing digit by pressing the ZERO key. Pressing the PRINT key or the TARE key will change the position of the flashing digit.

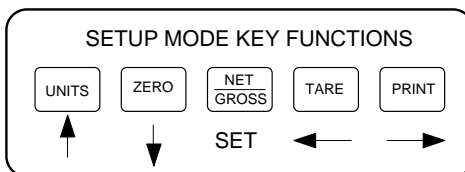

**Figure 6-1: Setup Menu Key Assignments**

4. After setting the exact value, press the NET/GROSS key to save the value.
5. If the calibration was successful, the display will show "EndC1" momentarily, then revert back up to F17. At this time it is suggested that the calibration values be recorded for future use (see Section 6.4).
6. If the calibration was *not* successful, one of the error messages below will appear. Take the indicated action to correct the problem, then perform a new calibration.

"Err0" - The calibration test weight or the adjusted keyed-in weight is larger than the full capacity of the scale. Change the calibration test weight or check the input data.

"Err1" - The calibration test weight or the adjusted keyed-in weight is smaller than 1% of the full capacity of the scale. Change the calibration test weight or check the input data.

"Err2" - The internal resolution of the scale is not high enough to accept the calibration value. Select a larger parameter for the Span Gain (F2). SEE APPENDIX C FOR MORE INFORMATION.

#### 6.4 VIEW CALIBRATION VALUES (F18)

**Note:** The values displayed in this procedure are valid only after a successful calibration has been performed using F16 and F17.

1. While in the Setup mode, scroll to "F 18", then scroll down once using the ZERO key to enter View calibration menu.
2. The display will momentarily show "CAL 0" followed by a value. This value is the **zero calibration value** and should be recorded in the table below. Press any key to continue.
3. The display will momentarily show "CAL 1" followed by another value. This value is the **span calibration value** and should also be recorded in the table below. Press any key to return to upper level (F18).

| INDICATOR | ZERO CALIBRATION VALUE | SPAN CALIBRATION VALUE |
|-----------|------------------------|------------------------|
| S/N:      |                        |                        |

**Table 6-1: Calibration Value Table**

#### 6.5 KEY-IN ZERO CALIBRATION VALUE (F19)

**Note:** This procedure is intended for emergency use only in the case of non-volatile memory loss. A valid zero calibration value, obtained from a successful F16 calibration procedure, must be used.

1. While in the Setup mode, scroll to "F 19", then scroll down once using the ZERO key.
2. The display will momentarily show "CAL 0", followed by a flashing zero. Use the four directional keys (shown in Figure 6-1) to adjust the displayed value to the zero calibration value.
3. After setting the exact value, press the NET/GROSS key to save the value.
4. The display will show "E CAL 0" momentarily, then revert back up to F19.

## 6.6 KEY-IN SPAN CALIBRATION VALUE (F20)

**Note:** This procedure is intended for emergency use only in the case of non-volatile memory loss. A valid span calibration value, obtained from a successful F17 calibration procedure, must be used.

1. While in the Setup mode, scroll to "**F 20**", then scroll down once using the ZERO key.
2. The display will momentarily show "**CAL 1**", followed by a flashing zero. Use the four directional keys (shown in Figure 6-1) to adjust the displayed value to the span calibration value.
3. After setting the exact value, press the NET/GROSS key to save the value.
4. If the entered value is greater than zero, the display will show "**E CAL 1**" momentarily, then revert back up to F20. If a value of zero is entered, the indicator will briefly show "**Err 5**", then revert back to the screen described above in Step # 2.

## CHAPTER 7: OPERATION

### 7.1 DISPLAY

The Model TI-1500/1520 indicator utilizes a 6-digit LED (Light Emitting Diode) display. Typically, LCD's are used for outdoor applications while LED's are used indoors where brightness is needed. Table 7-1 summarizes the display annunciators.

#### 7.1.1 LIGHT EMITTING DIODE (LED) DISPLAY

Figure 7-1 shows the display detail of the TI-1500/1520 LED display.

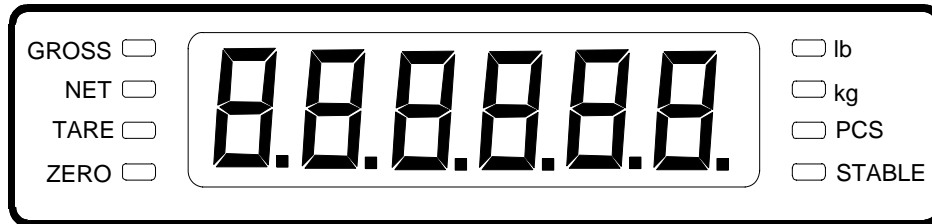

**FIGURE 7-1: TI-1500/1520 LED Display Detail**

| LED Annunciator | MEANING   |
|-----------------|---|
| ZERO            | Better known as the "Center of Zero" annunciator, this light is active whenever the displayed weight is within $\pm 0.25$ divisions of true zero. |
| NET             | Indicates that the indicator is displaying net weight.  |
| GROSS           | Indicates that the indicator is displaying gross weight.  |
| TARE            | Indicates that a tare weight has been established in the system.  |
| lb, kg, pcs     | Indicates the unit of the displayed weight. No unit means that the indicator is displaying weight in the custom unit.                             |
| STABLE          | This light is on whenever the scale is stable.  |

**TABLE 7-1: TI-1500 Series Annunciator Definitions**

## 7.2 KEYBOARD

The keyboard is composed of five function keys. Refer to Figure 7-2 for the overall layout and key locations.



FIGURE 7-2: Function Keys Layout

### 7.2.1 FUNCTION KEYS

**Units** – This key toggles the indicator among the available weight units if enabled in the Setup (“F”) menu. Available weight units include lb, kg, pieces and custom unit .See Chapter 4 for more information.

**Zero** - This key sets the indicator to display zero provided the following conditions are met:

1. The indicator is displaying Gross weight.
2. The displayed weight is within the zero reset range that is programmed in F4 of the Setup (“F”) Menu.
3. The scale is not in motion.
4. The scale is not in overload (see Appendix D for error codes).

**Net/Gross** - This key toggles the indicator between Gross weight and Net weight only if a Tare has been established.

**Tare** - This key is used to establish a Tare provided the following conditions are met:

1. The indicator is not at or below Gross zero.
2. The scale is not in motion.
3. The scale is not in overload (see Appendix D for error codes).

**Print** - This key is used to send weight information out to the COM1 serial port provided the following conditions are met:

1. The scale is not in motion.
2. The scale is not in overload (see Appendix D for error codes).

## 7.3 GENERAL SCALE OPERATION

### 7.3.1 WEIGHING AN ITEM

1. Select the desired weighing unit by pressing the UNITS key until that unit is indicated on the display.
2. If necessary, press the ZERO key to obtain a weight reading of zero.
3. Place the object to be weighed on the scale’s platter and allow the weight indication to stabilize. If the item weight exceeds the scale’s weight capacity, it displays “ ”.
4. Read the weight shown on the display.

### 7.3.2 TARING AN ITEM

To weigh an item in a container, the weight of that container must first be subtracted from the overall weight to obtain an accurate weight reading. This is known as taring.

1. Select the desired weighing unit by pressing the UNITS key until that unit is indicated on the display.
2. If necessary, press the ZERO key to obtain a weight reading of zero.

3. Place the empty container on the scale's platter and allow the weight indication to stabilize.
4. Press the TARE key. The display shows zero weight and turns the NET annunciator on.
5. Place the material to be weighed in the container and allow the weight indication to stabilize.
6. Read the weight shown on the display.
7. You may toggle between the gross weight and the net weight by pressing the NET/GROSS key.

### 7.3.3 PIECE COUNTING

This mode is used to indicate the number of pieces of an item you have placed on the scale's platform and is accessed by pressing the UNITS key. To ensure accuracy, the parts you are counting must be consistent in weight.

The indicator uses the sampling method to determine the average piece weight (APW) of the items you wish to count. When sampling items, always count the parts in your hand and place them on the platform all at once. If the APW of the items is too light or the total weight of the sample is too light, accuracy cannot be guaranteed. You will get an error message, but piece counting will still be allowed.

1. Press the UNITS key until "PCS" is indicated on the display. If a previous sample has not been taken, the indicator will display "10 0". If a previous sample has been taken, the indicator will display the current number of pieces on the platform.
2. If the items you will be counting require a container, you must first tare the container off by pressing the TARE key.
3. If the screen does not show "10 0", press the TARE key once. The indicator is prompting you to place ten identical items on the platform.  
**NOTE:** If you wish to change the sample number, simply press the NET/GROSS key repeatedly until the desired sample number appears. Available choices are 5, 10, 25, 50 and 100.
4. Place the sample items on the platform all at once and allow the weight indication to stabilize. Once this is done, the zero indicated after the sample number will change to a "-". For example, "10 -".
5. Press the NET/GROSS key to take the sample. If the sample size is large enough, the indicator now displays the number of pieces on the platform. If it does not, the indicator briefly displays "Add" and automatically increments the sample size. Repeat Step #4 with the new sample size.

**NOTE:** If the indicator continues to display "Add" even after sampling 100 pieces, the unit weight of the items you wish to count is too light for your scale to process accurately.

6. To exit the piece count mode, press the UNITS key. The APW will remain in scale memory until you repeat Steps # 2 or #3.

## CHAPTER 8: LEGAL FOR TRADE SEALING

### 8.1 ABS ENCLOSURE

The TI-1500 indicator in the ABS enclosure can be sealed for commercial (Legal for Trade) applications as follows.

1. Power off the indicator by unplugging the power source.
2. On the back of the indicator, locate the Setup/Calibration Slide Switch Cover Plate (see illustration below).
3. Thread a wire security seal through both drilled head screws securing the calibration switch cover.

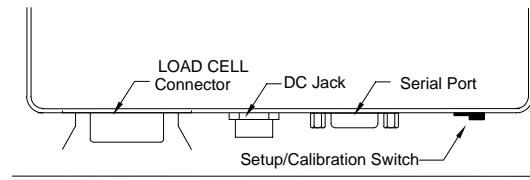

**Figure 8-1: TI-1500 ABS Rear Panel**

### 8.2 STAINLESS STEEL ENCLOSURE

Indicators in the stainless steel enclosure can be sealed for commercial (Legal for Trade) applications as follows.

1. Power off the indicator.
2. On the rear cover of the indicator, locate the calibration switch cover.
3. Thread a wire security seal through both drilled head screws securing the calibration switch cover as well as the two drilled head screws holding on the rear panel.

#### **Older units**

1. Power off the indicator.
2. Locate the two adjacent drilled head screws securing the rear cover.
3. Thread a wire security seal through two drilled head screws securing the rear cover.



## APPENDIX A: SPECIFICATIONS

### ANALOG SPECIFICATIONS

|                                |  |
|--------------------------------|--|
| Full Scale Input Signal        | 30mV, including dead load                              |
| Minimum Sensitivity - Non H-44 | 0.4 $\mu$ V / grad                                     |
| Minimum Sensitivity - H-44     | 1.0 $\mu$ V / grad                                     |
| Input Impedance                | 30M $\Omega$ , typical                                 |
| Internal Resolution            | Approximately 260,000 counts                           |
| Display Resolution             | 50,000 display divisions max                           |
| Measurement Rate               | 10 Meas/sec, nominal                                   |
| System Linearity               | Within 0.02% of FS                                     |
| Calibration Method             | Software Calibration, with long term storage in EEPROM |
| Excitation Voltage             | +10VDC, 8 x 350 $\Omega$ load cells                    |

### DIGITAL SPECIFICATIONS

|                   |  |
|-------------------|--|
| Microcomputer     | Intel 80C32                                  |
|                   | Program Memory: 64K x 8, external to $\mu$ C |
|                   | EEPROM: 64 x 16, external to $\mu$ C         |
| Digital Filtering | Software selectable                          |

### SERIAL COMMUNICATIONS

|             |  |
|-------------|--|
| Serial Port | Full Duplex, 1200, 2400, 4800, 9600 Baud |
|             | 8 data bits, no parity, 1 stop bit       |
|             | 7 data bits, odd parity, 1 stop bit      |
|             | 7 data bits, even parity, 1 stop bit     |
|             | 7 data bits, no parity, 2 stop bits      |

### OPERATOR INTERFACE

|                      |  |
|----------------------|--|
| Display - TI-1500/20 | 1" (25 mm) 7-segment, Led, 6 Digit             |
| Additional Symbols   | Net, Gross, Stable, Tare, lb, kg, Pieces, Zero |
| Keyboard             | 5-key flat membrane panel                      |

### POWER

|                                   |                                     |
|-----------------------------------|-------------------------------------|
| Standard AC Input                 | 110/220 VAC , 50/60 Hz              |
| Optional AC Adapter               | 12 VDC, 800mA Female                |
| DC Power Consumption - TI-1500/20 | 200mA + 30mA/350 $\Omega$ Load Cell |

### ENVIRONMENTAL

|                       |                |
|-----------------------|----------------|
| Operating Temperature | -10° to +40° C |
| Storage Temperature   | -25° to +70° C |

### MECHANICAL

|  |   |
|--|---|
| Overall Dimensions (L x W x H) – TI-1500 | 12.2" x 3.9" x 8.1" (310mm x 100mm x 205mm) |
| Overall Dimensions (L x W x H) – TI-1520 | 11.8" x 3.9" x 7.7" (300mm x 100mm x 195mm) |

### APPROVALS

|                                    |  |
|------------------------------------|--|
| NTEP                               | Class III/IIIL COC 99-017  |
| Canadian Legal Branch of Metrology | Class III Approval No. AM-5305   |
| European CE Mark                   | Meets test requirements for:<br>EN55011for Class B ISM<br>EN50082-1 for Residential, Commercial and Light Industrial |

## APPENDIX B: SERIAL PORT INFORMATION

### B.1 COM1 MODES

#### B.1.1 FULL DUPLEX MODE

The Full Duplex Mode for COM1 provides a Demand serial transmission mode. The Demand mode allows control from a host device, usually a PC, and can be activated by pressing the PRINT key on the indicator's front panel. Figure B-1 shows a suggested cable diagram for interface to a PC. Figure B-2 shows the serial data format for the Demand Mode.

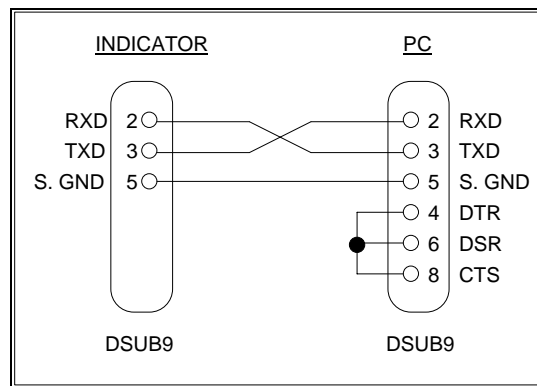

FIGURE B-1. Cable Diagram for Indicator to IBM PC

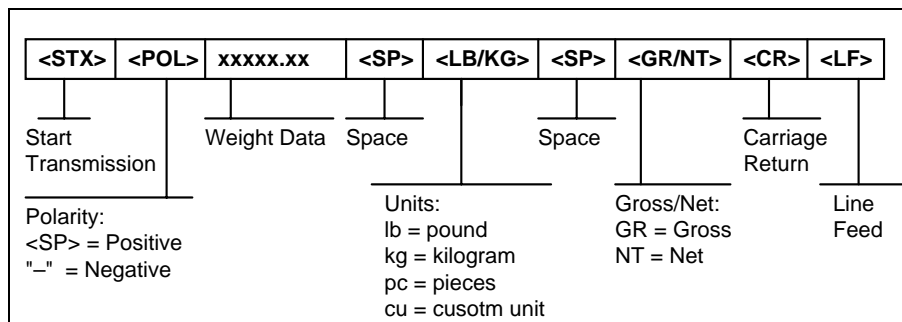

FIGURE B-2. Consolidated Controls Demand Mode

### B.1.1.1 RECOGNIZED HOST COMMANDS

“**P**” - This command is sent to the indicator to print the indicated display. The indicator will not respond if the scale is in motion, positive overload or negative overload.

“**Z**” - This command is sent to the indicator to zero the scale. The indicator will not respond if the scale is in motion, positive overload or negative overload. The indicator will also not respond if it is not in gross mode or within the zero range specified in F4 of the Setup Menu.

“**T**” - This command is sent to the indicator to tare the scale. The indicator will not respond if the scale is in motion, positive overload or negative overload. The indicator will also not respond if it is displaying a negative gross value.

“**G**” - This command is sent to the indicator to revert to gross mode. The indicator will not respond if the scale is in motion, positive overload or negative overload. The indicator will also not respond if it is not in net mode.

“**N**” - This command is sent to the indicator to revert to net. The indicator will not respond if the scale is in motion, positive overload or negative overload. The indicator will also not respond if it is not in gross mode or a tare has yet to be established.

“**C**” - This command is sent to the indicator to toggle among the configured units.

### B.1.2 PRINT TICKET MODE

The Print Ticket Mode is designed specifically for a serial printer. Figure B-3 shows the fixed format of the print ticket.

For printers with limited buffers, this mode supports DTR pin handshaking by enabling A7 in the User Menu. The DTR pin from the serial printer is wired to the indicator's RXD pin which then functions as a CTS pin. Figure B-4 shows a suggested cable diagram for interfacing to a serial printer. Refer to the printer's user manual to confirm whether or not it supports the DTR pin. The cable depicted in Figure B-4 can be used even if the printer does not support the DTR pin.

#### NOTES:

1. The TARE and NET fields are not printed unless a tare has been established in the system.
2. The ID number field is not printed if it is disabled in A4 of the User Menu.
3. The Time field is not printed if it is disabled in A8 of the User Menu.
4. The Date number field is not printed if it is disabled in A11 of the User Menu.
5. The PCS and APW fields are not printed unless the indicator is in piece count mode.

```

DATE    06/05/98
TIME    12:34 PM
ID      123456
GROSS   25.00 lb
TARE    1.48 lb
NET     23.52 lb
PCS     1234
APW     0.019060 lb

```

**FIGURE B-3. Print Ticket**

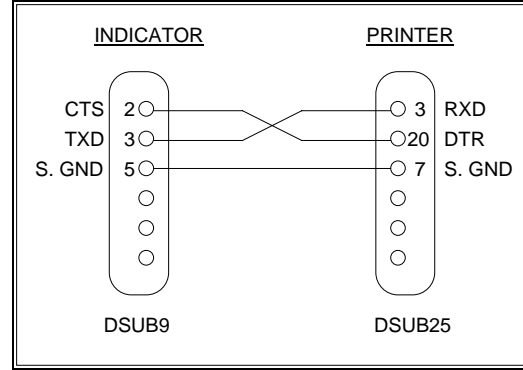
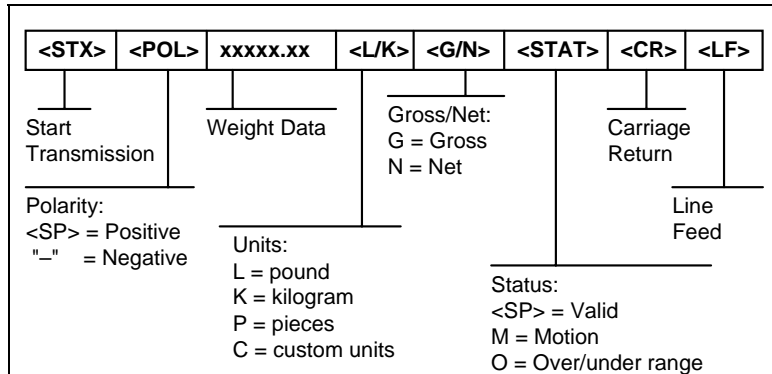

**FIGURE B-4. Cable Diagram for Indicator to Printer**

## B.2 COM2 MODE

### B.2.1 SIMPLEX MODE

The Simplex Mode provides a Continuous serial transmission mode. The Continuous mode is used to interface to computers, scoreboards, and other remote devices requiring constant data updating. The transmission occurs at the end of each display update. Figure B-5 shows the serial data format for Continuous Mode.



**FIGURE B-5. Consolidated Controls Continuous Mode**

## APPENDIX C: DETERMINING PROPER SPAN GAIN (F2)

### C.1 SPAN GAIN OVERVIEW

The Span Gain parameter found in F2 of the Setup Menu is directly related to the ADC (Analog to Digital Converter) integration time. This means that the lower the setting, the higher the number of measurements per second. A span gain setting of **25** produces about 25 to 30 measurements per second, while a span gain of **200** produces only about 3 or 4 measurements per second.

There is really no wrong setting for span gain – except in two cases. Using a low setting for a high resolution, low output system could yield instability. Using a high setting in a high output system could yield non-linearity.

### C.2 SETTING THE INITIAL VALUE FOR SPAN GAIN

1. Determine the number of desired external graduations and choose the corresponding value listed in Table C-1 under the number closest to your full-scale input range in millivolts.
2. Enter the Setup Menu and save this number for the Span Gain parameter in F2.
3. Perform a system calibration. If the calibration proves unsuccessful, or you wish to view the internal counts, proceed to the next set of instructions.

### C.3 VIEWING THE INTERNAL COUNTS

1. Enter the zero calibration menu (F16) and follow steps 1 to 3, **but do not save the zero point**.
2. After pressing **ZERO** to zero the offset, place the test weight(s) on the platform. The displayed count is the internal count. If the count remains on zero, check your load cell connections.
3. At full scale, the displayed count should be a minimum of 2 times the desired external graduations. However, for maximum stability, a ratio of 6:1 or higher is recommended.
4. If the displayed count is large enough, remove the test weight(s), re-zero the indicator if necessary, and proceed with the calibration. If the displayed number is *not* large enough, increase the Span Gain to the next highest choice in the Setup Menu and re-calibrate.

| # of External Grads | Full Scale Input Range (mV/V) |     |            |            |            |            |           |           |           |           |           |           |           |           |           |
|---------------------|-------------------------------|-----|------------|------------|------------|------------|-----------|-----------|-----------|-----------|-----------|-----------|-----------|-----------|-----------|
|                     | 0.2                           | 0.4 | 0.6        | 0.8        | 1.0        | 1.2        | 1.4       | 1.6       | 1.8       | 2.0       | 2.2       | 2.4       | 2.6       | 2.8       | 3.0       |
| 500                 | 25                            | 25  | 25         | 25         | 25         | 25         | 25        | 25        | 25        | 25        | 25        | 25        | 25        | 25        | 25        |
| 1,000               | 50                            | 25  | 25         | 25         | 25         | 25         | 25        | 25        | 25        | 25        | 25        | 25        | 25        | 25        | 25        |
| 1,500               | 75                            | 50  | 25         | 25         | 25         | 25         | 25        | 25        | 25        | 25        | 25        | 25        | 25        | 25        | 25        |
| 2,000               | 100                           | 50  | 50         | 25         | 25         | 25         | 25        | 25        | 25        | 25        | 25        | 25        | 25        | 25        | 25        |
| 2,500               | 150                           | 75  | 50         | 50         | 25         | 25         | 25        | 25        | 25        | 25        | 25        | 25        | 25        | 25        | 25        |
| 3,000               | 150                           | 75  | 50         | 50         | 50         | 25         | 25        | 25        | 25        | 25        | 25        | 25        | 25        | 25        | 25        |
| 4,000               | 200                           | 100 | 75         | 50         | 50         | 50         | 50        | 25        | 25        | 25        | 25        | 25        | 25        | 25        | 25        |
| 5,000               | –                             | 150 | 100        | 75         | 50         | 50         | 50        | 50        | 50        | 25        | 25        | 25        | 25        | 25        | 25        |
| 6,000               | –                             | 150 | 100        | 75         | 75         | 50         | 50        | 50        | 50        | 25        | 25        | 25        | 25        | 25        | 25        |
| 8,000               | –                             | 200 | 150        | 100        | 75         | 75         | 75        | 50        | 50        | 50        | 50        | 50        | 50        | 50        | 25        |
| <b>10,000</b>       | –                             | –   | <b>200</b> | <b>150</b> | <b>100</b> | <b>100</b> | <b>75</b> | <b>75</b> | <b>75</b> | <b>50</b> | <b>50</b> | <b>50</b> | <b>50</b> | <b>50</b> | <b>50</b> |
| 12,000              | –                             | –   | 200        | 150        | 150        | 100        | 100       | 75        | 75        | 75        | 50        | 50        | 50        | 50        | 50        |
| 15,000              | –                             | –   | –          | 200        | 150        | 150        | 100       | 100       | 100       | 75        | 75        | 75        | 75        | 50        | 50        |
| 20,000              | –                             | –   | –          | –          | 200        | 200        | 150       | 150       | 150       | 100       | 100       | 100       | 75        | 75        | 75        |
| 30,000              | –                             | –   | –          | –          | –          | –          | 200       | 200       | 200       | 150       | 150       | 150       | 150       | 100       | 100       |
| 40,000              | –                             | –   | –          | –          | –          | –          | –         | –         | –         | 200       | –         | –         | 150       | 150       | –         |

**Table C-1: Minimum Recommended (6:1) Span Gain Table**

## APPENDIX D: DISPLAYED ERROR CODES

| CODE   | MODE                                 | MEANING / POSSIBLE SOLUTION  |
|--------|--------------------------------------|--|
| □□□□□□ | Normal Operating Mode                | Gross Overload. A weight greater than the rated capacity has been applied to the scale. Remove the weight from the platter or try re-calibrating the scale. Otherwise, check for a bad load cell connection or possible load cell damage due to overloading. |
| Err 0  | Span Calibration Mode (F17)          | Keyed-in weight value is less than 1% of full-scale capacity. Use a larger test weight or check keyed-in value.  |
| Err 1  | Span Calibration Mode (F17)          | Keyed-in weight value is larger than full-scale capacity. Use a smaller test weight or check keyed-in value.   |
| Err 2  | Span Calibration Mode (F17)          | There is not enough load cell signal to produce the internal counts necessary to properly calibrate the scale. First check all load connections. Use F16 mode to view internal counts. See Appendix C for more information.                                  |
| Err 3  | All Modes                            | Non-volatile memory read error. One or more setup parameters have been lost.   |
| Err 4  | All Modes                            | Non-volatile memory write error. Indicator needs service.  |
| Err 5  | Key-in Span Calibration Mode (F20)   | You have attempted to enter a zero value for C1. Enter a known calibration value greater than zero.  |
| Err 7  | Initialization                       | No reading from the ADC. Make sure there is a load cell(s) connected to the indicator at start-up.   |
| Err 9  | Normal Operating Mode                | Span calibration value has been lost. Re-calibrate the scale.  |
| Err 10 | Initialization or Setting Code Entry | Indicator cannot read serial number. Indicator must be returned for service.   |
| Err 11 | Initialization                       | Serial number mismatch. Re-enter setting code from product ID tag.   |
| Err 12 | Initialization or Setting Code Entry | Invalid setting code. Re-enter proper setting code from product ID tag.  |
| Err 13 | Setting Code Entry                   | Non-volatile memory is in write-protect mode. Toggle position of Setup/Calibration Switch or JP2 jumper (See Chapter 3).   |

**Note:** Contact Service Department at Transcell for instructions on how to re-enter setting code.