



## PORTABLE SCALES

---

This highly durable scale is designed with simplicity and portability in mind. In just a few minutes the entire system can be setup and ready to weigh. The standard system includes two weigh bars both with built in handles and 20' of homerun cable, quick connectors, and a NEMA 4X stainless steel digital indicator with backlight.

This fully portable system can be used in livestock weighing, under conveyors, under tanks, hoppers and many other applications. Standard capacity is 2,500 lb per bar with a total system capacity of 5,000 lb



# WEIGH BEAM

## Standard Features & Benefits:

- **LIGHTWEIGHT & PORTABLE-**  
Can be positioned to weigh easily, or store when not in use. Each Weigh Beam is fitted with an easy carry handle for TOTAL PORTABILITY
- **WATERPROOF QUICK CONNECTS-** provides quick and easy setup and break down
- **LOW PROFILE-**  
Less than 3" high. Supplied in pairs. Total capacity of beams is 5,000 pounds per pair
- **DISPLAY-** Backlit LCD
- **AUTO SHUTOFF-** Extends battery life
- **AUTO WEIGHT CAPTURE-** For unstable and live loads
- **SIMPLE OPERATION-** The 5 button keyboard provides a simple Zero, lb/kg, Net/Gross, push button Tare, and Print key
- **POWER REQUIREMENTS-** Operates on AC Adapter or rechargeable Lead Acid Battery
- **APPROX. LEAD ACID BATTERY LIFE-** 29 hours\*
- **FULL DUPLEX RS-232 PORT-**  
The Full Duplex RS-232 output provides on demand output to a printer, computer, or other compatible devices

\*Battery life will vary depending on number and type of load cells used, duration of backlight, temperature, and other factors.

## Specifications:

<b>Indicator Housing:</b> 304 Stainless Steel	<b>Capacity:</b> 5000 lb x 1 lb
<b>Beams:</b> Carbon steel with high grade epoxy paint finish	<b>Over Load Protection:</b> 200% of full scale capacity
<b>Feet:</b> Non-skid hard rubber, 3" diameter	<b>Serial port:</b> Full duplex, RS-232
<b>Display:</b> 6-digit Liquid Crystal Display	<b>Main Power Source:</b> AC adapter, 12 VDC, 800 mA, or rechargeable battery 6V, 3Ah
<b>Keypad:</b> 5-Key tactile keypad	<b>Net Weight:</b> 65 lbs
<b>Operating Temperature:</b> 14°F to 104°F (-10°C to 40°C)	<b>Shipping Weight:</b> 75 lbs
<b>Cable length:</b> 20 Feet	

## Dimensions:

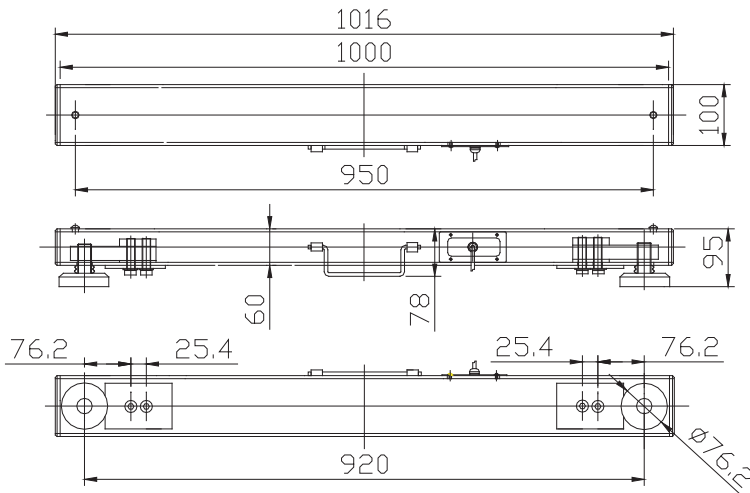

Version 1.3 , 6/18/08

**YOUR AUTHORIZED TRANSCCELL DEALER IS:**

*Specifications and features subject to change without notice.*



**TRANSCCELL TECHNOLOGY, INC.**

975 Deerfield Pkwy, Buffalo Grove, IL 60089  
Tel (847) 419-9180 Fax (847) 419-1515

**(800) 503-9180**

www.transcell.net